

### Kabebari batten detail

Profile: Āchi 40x40mm

Base: 0.207kg/m

Cover: 0.535kg/m

Total: 0.742kg/m

Batten thickness: 1.0mm

End cap thickness: 2.0mm

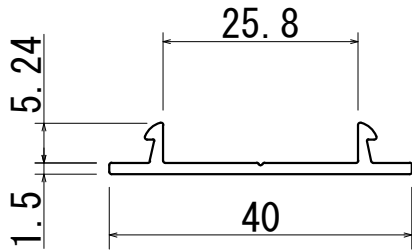
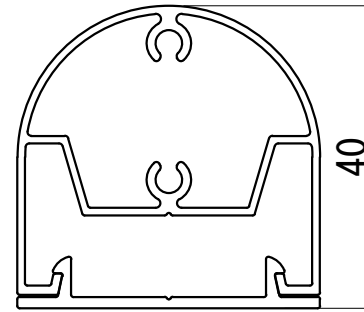
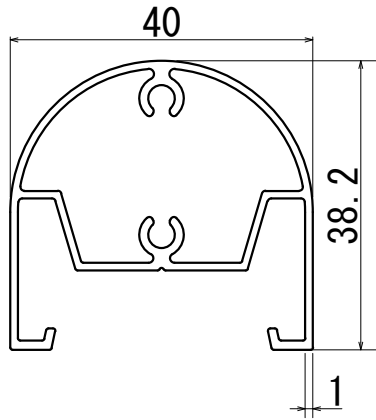

### Endcap detail

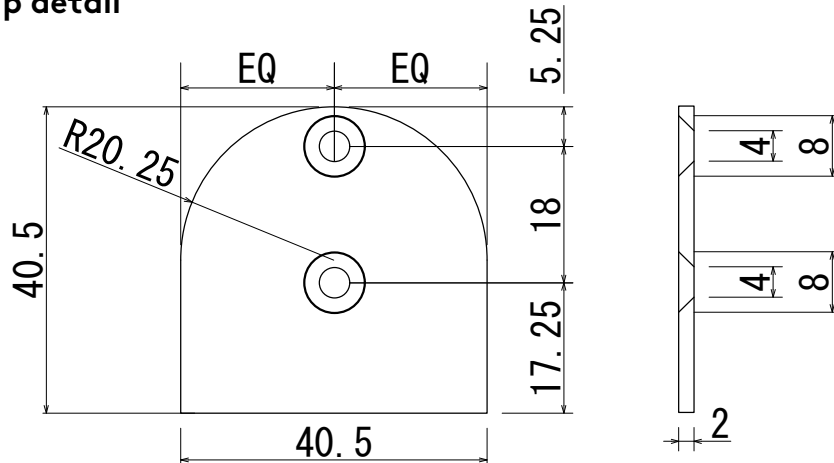

### Installation detail ⚠

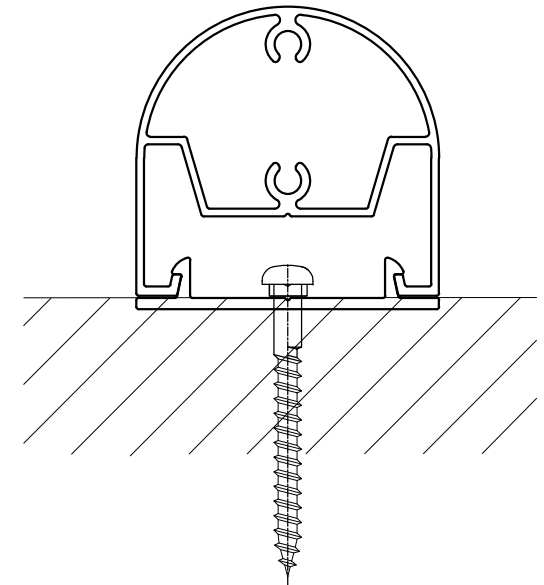

⚠ 3

⚠ 2

⚠ 1

**Install** Never strike extrusion directly with a hammer or rubber mallet. Use a pine plank between the tool and the extrusion to avoid surface damage or denting.

**End caps** Screw fix to secure aluminium end caps to battens.

No. DATE

Product Name

Project Name

Creation Date

Page

Scale

Projection

Ever Art Wood - Kabebari

Āchi 40x40

1 of 37

1:1



Approval

Chek

Drawing

Design

Customer

Distributor

Manufacturer

**covet**



### Kabebari batten detail

#### Profile: Kogarana 24x27mm

Base: 0.099kg/m

Cover: 0.224kg/m

Total: 0.323kg/m

Batten thickness: 0.9mm

End cap thickness: 2.3mm

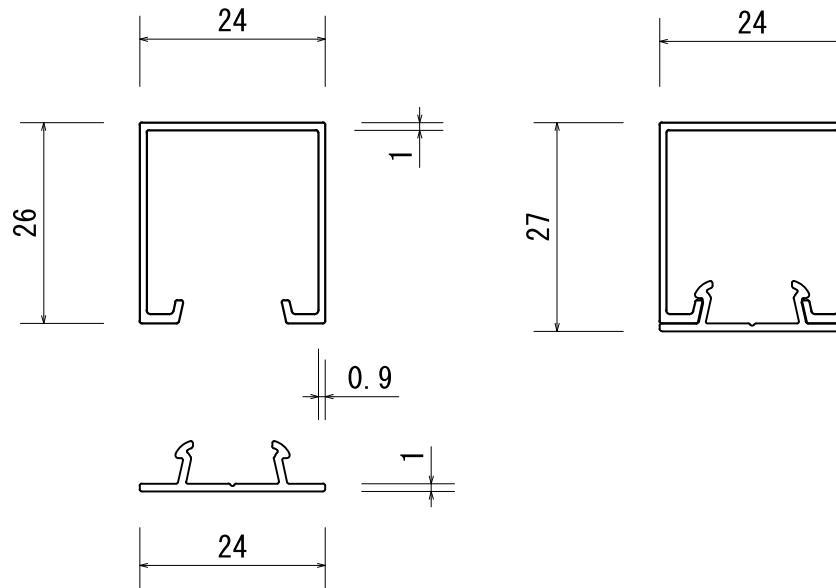



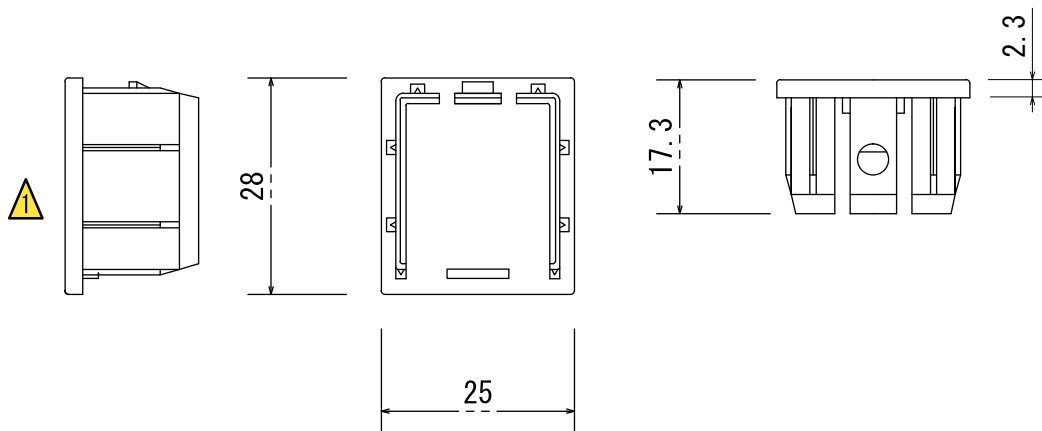

### Endcap detail

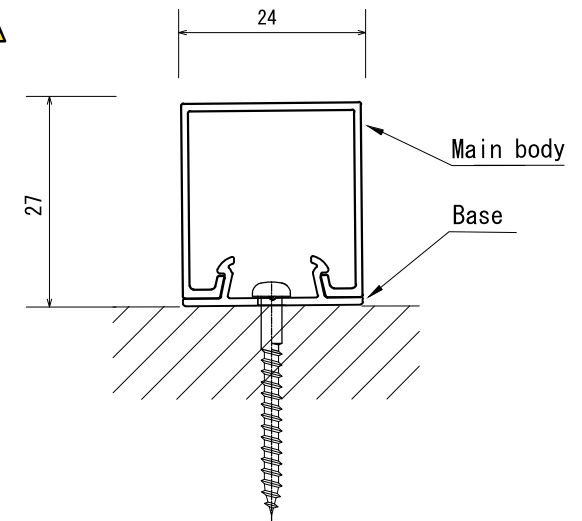

### Installation detail



			Product Name				Project Name	Creation Date	Page	Scale	Projection
	<b>Install</b>	Never strike extrusion directly with a hammer or rubber mallet. Use a pine plank between the tool and the extrusion to avoid surface damage or denting.	Ever Art Wood - Kabebari				Kogarana 24x27		2 of 37	1:1	
	<b>End caps</b>	Secure to batten with screw or exterior grade adhesive (Sikaflex).	Approval	Chek	Drawing	Design	Customer	Distributor		Manufacturer	
No.	DATE							<b>covet</b>			

### Kabebari batten detail

**Profile: Rectangle 30x50mm**

Base: 0.348kg/m

Cover: 0.390kg/m

Total: 0.738kg/m

Batten thickness: 1.2mm

End cap thickness: 3.0mm

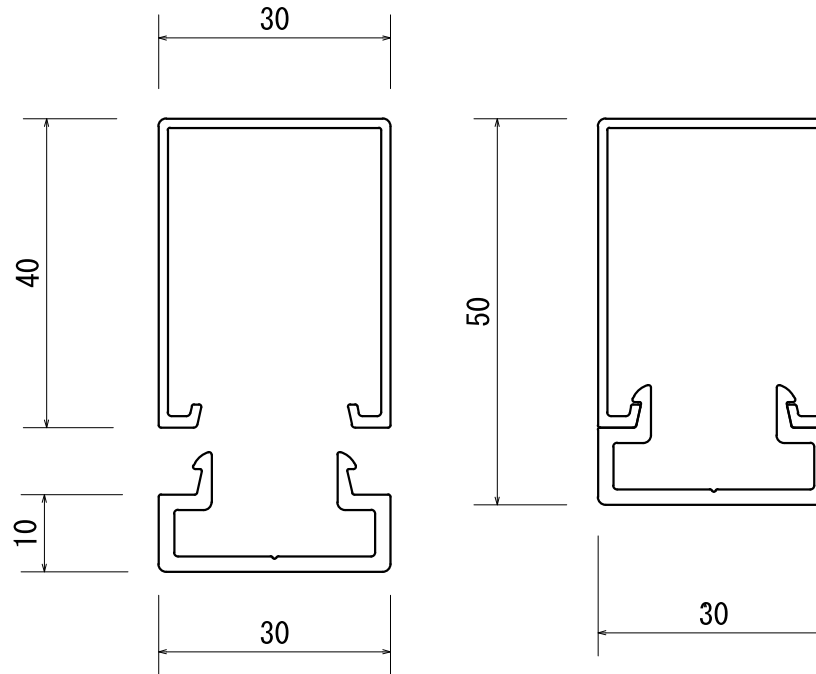

### Endcap detail

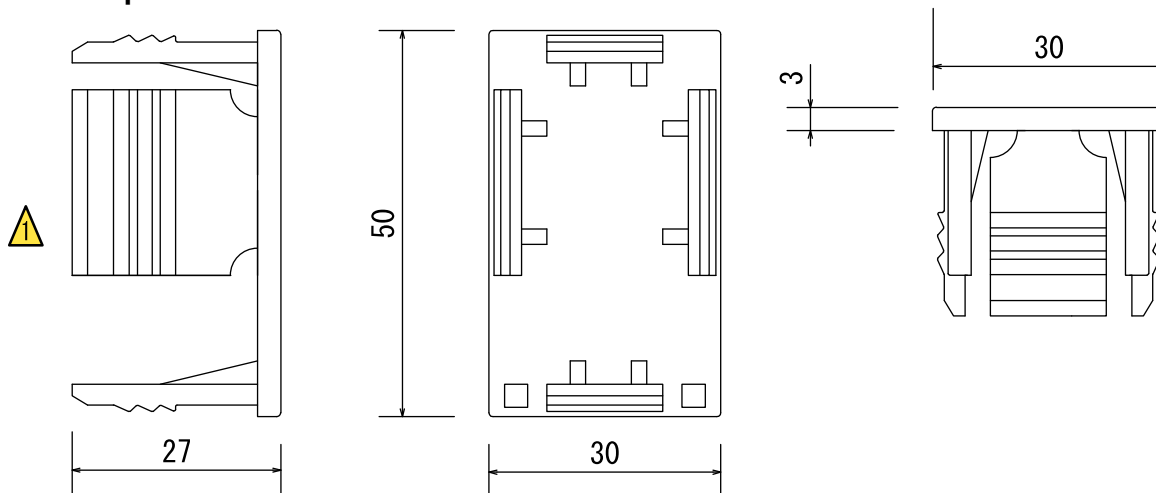



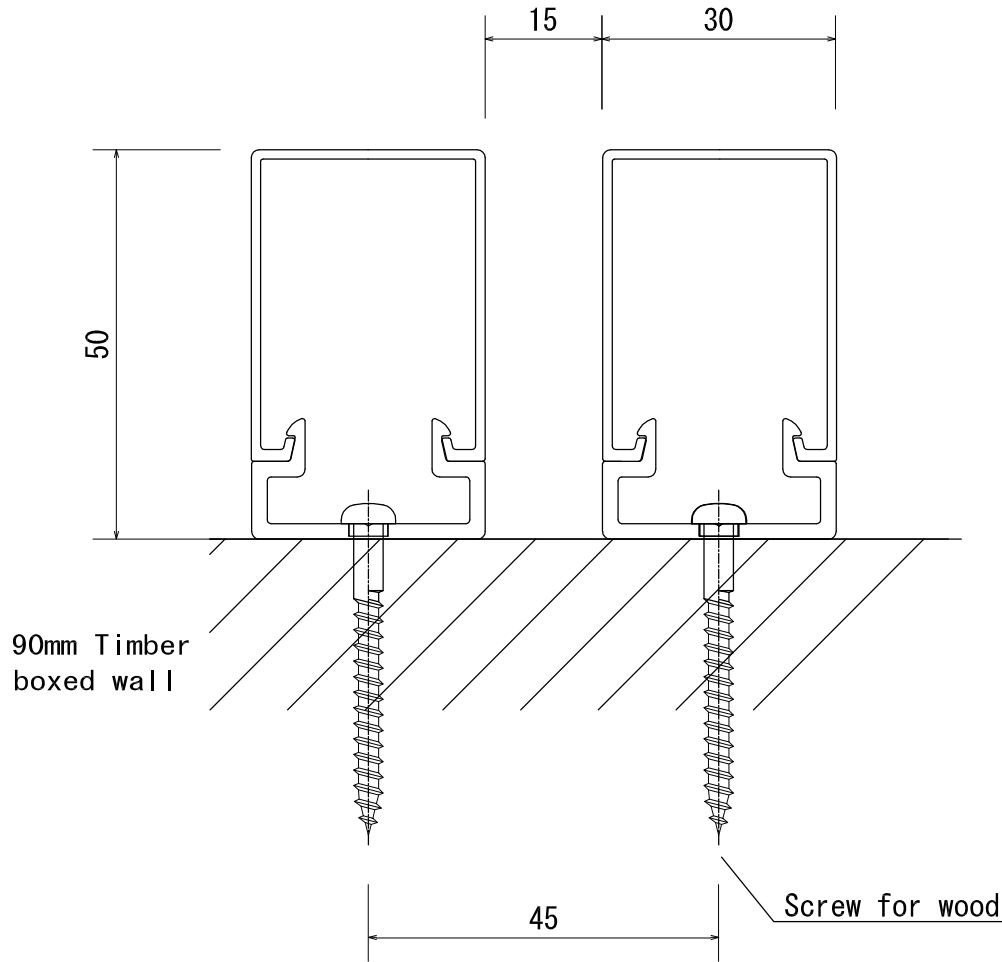

3			Product Name				Project Name	Creation Date	Page	Scale	Projection
2	<b>Install</b>	Never strike extrusion directly with a hammer or rubber mallet. Use a pine plank between the tool and the extrusion to avoid surface damage or denting.	Ever Art Wood - Kabebari				Rectangle 30x50		3 of 37	1:1	⊕
1	<b>End caps</b>	Secure to batten with screw or exterior grade adhesive (Sikaflex).	Approval	Chek	Drawing	Design	Customer	Distributor		Manufacturer	
No.	DATE							<b>covet</b>		<b>TAKASHO</b>	

### Installation detail



### Kabebari Batten Installation Guide

- Aluminium can be damaged if mishandled. Never strike directly with a hammer or rubber mallet. Use a pine plank between the striking rubber mallet and the extrusion to avoid surface damage or denting.
- Cut aluminium with a drop saw using an aluminium blade.
- Always cap ends of extrusions with supplied end caps or a flashing to avoid moisture ingress.
- Plastic end caps must be securely inserted with screws supplied or sikaflex applied to the inside of the extrusion before inserting. This will prevent slippage of the extrusion.
- Metal end caps (painted) must be screwed to the extrusion.
- All end caps can only be applied to straight 90 degree cuts. They cannot be applied to angle end cuts.
- Ensure appropriate screws are used to suit the substrate you are fastening to. It is important to use stainless steel or bi-metal screws for all metal surfaces impacted when fastening (i.e. furring channels, top hats, steel frames). This will prevent galvanic reaction between the screw/substrate and aluminium extrusion.
- Fasten at maximum 1 metre spans. Please contact Covet for further information.
- Always fasten the male (base) section first. The female (top section) clips over the top. They can also slide on if necessary.

			Product Name				Project Name	Creation Date	Page	Scale	Projection
	<b>Install</b>	Never strike extrusion directly with a hammer or rubber mallet. Use a pine plank between the tool and the extrusion to avoid surface damage or denting.	Ever Art Wood - Kabebari				Rectangle 30x50		4 of 37	1:1	
	<b>End caps</b>	Secure to batten with screw or exterior grade adhesive (Sikaflex).	Approval	Chek	Drawing	Design	Customer	Distributor		Manufacturer	
No.	DATE							<b>covet</b>			

### Kabebari batten detail

**Profile: Rectangle 30x85mm**

Base: 0.348kg/m

Cover: 0.712kg/m

Total: 1.060kg/m



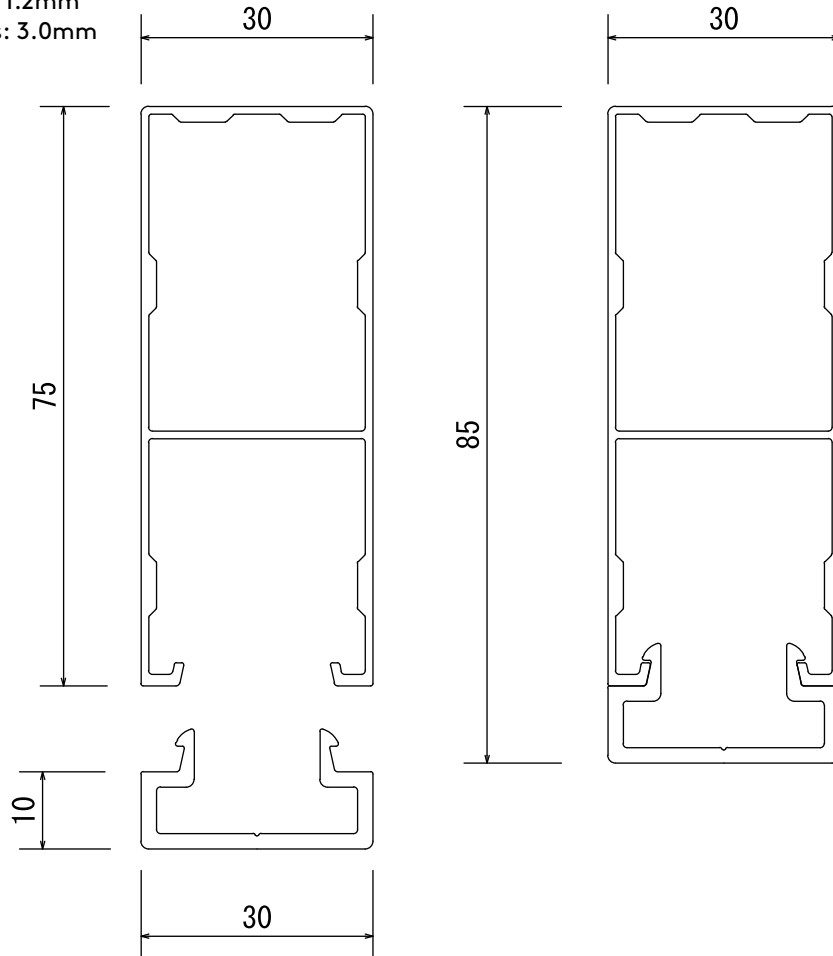

Batten thickness: 1.2mm

End cap thickness: 3.0mm

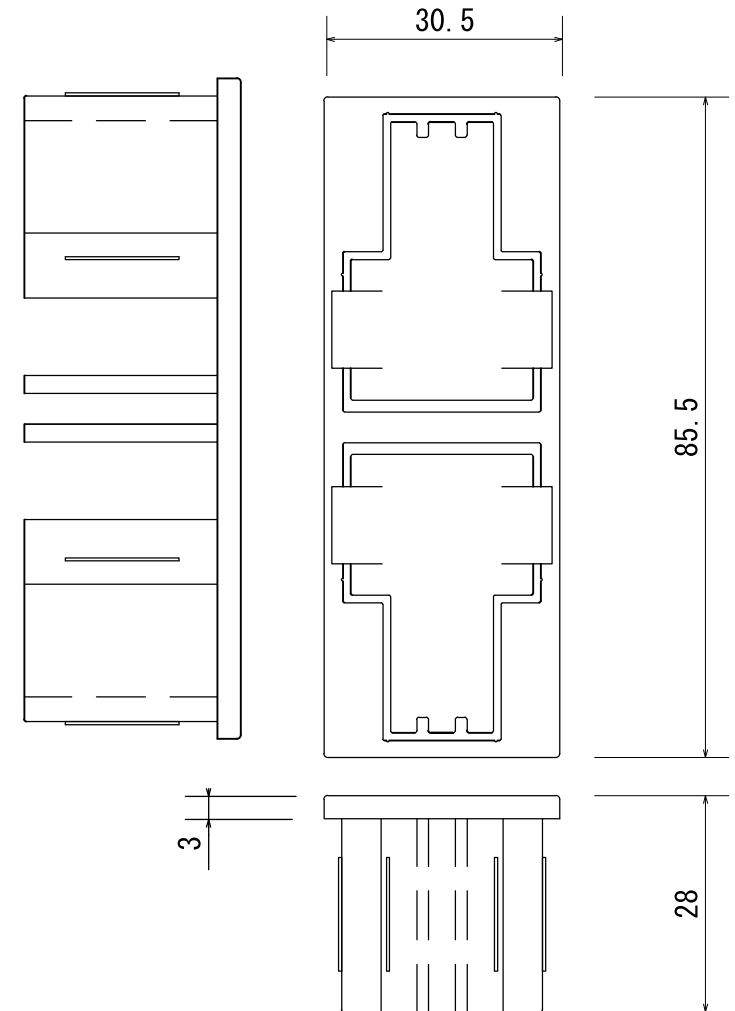

### Endcap detail





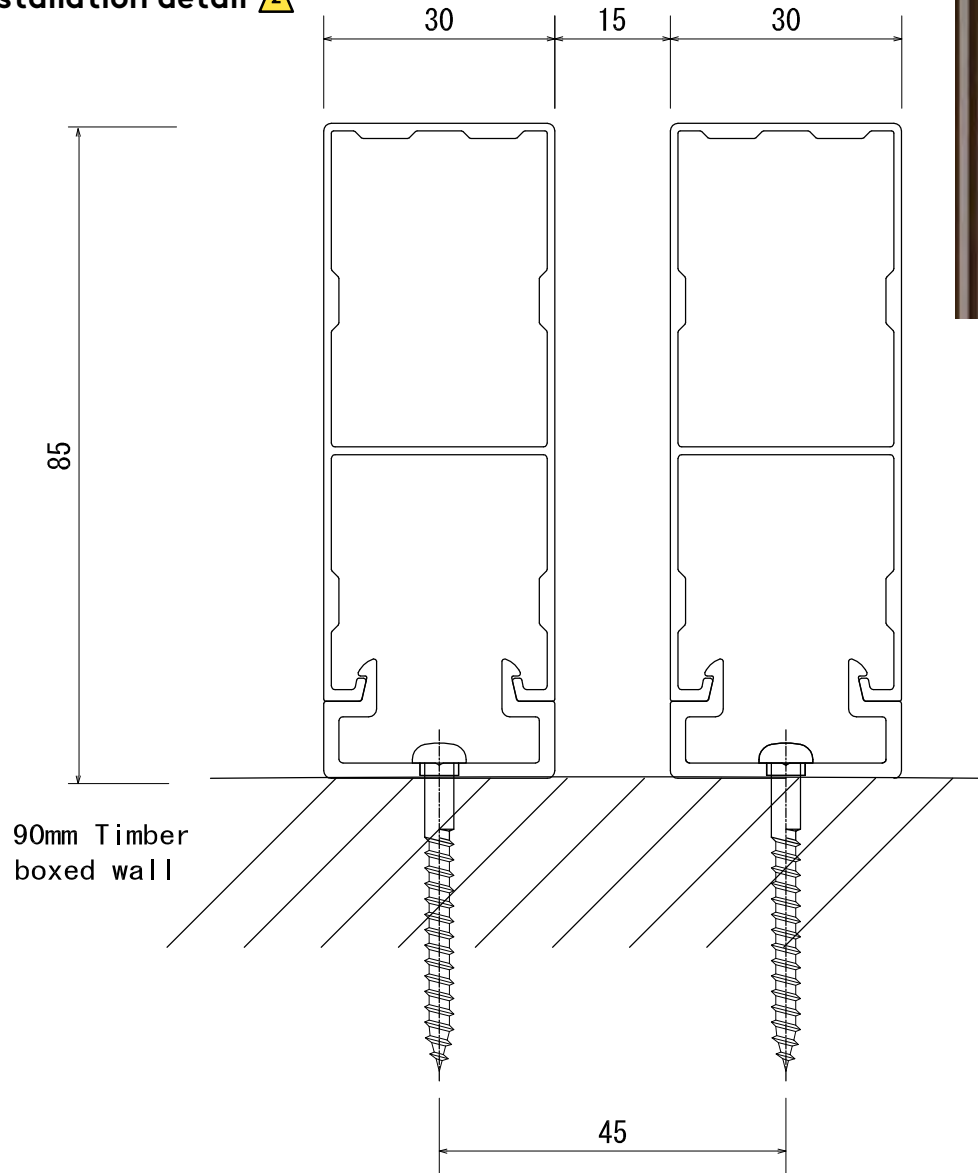

			Product Name				Project Name	Creation Date	Page	Scale	Projection
	<b>Install</b>	Never strike extrusion directly with a hammer or rubber mallet. Use a pine plank between the tool and the extrusion to avoid surface damage or denting.	Ever Art Wood - Kabebari				Rectangle 30x85		5 of 37	1:1	
	<b>End caps</b>	Secure to batten with screw or exterior grade adhesive (Sikaflex).	Approval	Chek	Drawing	Design	Customer	Distributor		Manufacturer	
No.	DATE							<b>covet</b>			

Installation detail 



**Kabebari Batten Installation Guide**

- Aluminium can be damaged if mishandled. Never strike directly with a hammer or rubber mallet. Use a pine plank between the striking rubber mallet and the extrusion to avoid surface damage or denting.
- Cut aluminium with a drop saw using an aluminium blade.
- Always cap ends of extrusions with supplied end caps or a flashing to avoid moisture ingress.
- Plastic end caps must be securely inserted with screws supplied or sikaflex applied to the inside of the extrusion before inserting. This will prevent slippage of the extrusion.
- Metal end caps (painted) must be screwed to the extrusion.
- All end caps can only be applied to straight 90 degree cuts. They cannot be applied to angle end cuts.
- Ensure appropriate screws are used to suit the substrate you are fastening to. It is important to use stainless steel or bi-metal screws for all metal surfaces impacted when fastening (i.e. furring channels, top hats, steel frames). This will prevent galvanic reaction between the screw/substrate and aluminium extrusion.
- Fasten at maximum 1 metre spans. Please contact Covet for further information.
- Always fasten the male (base) section first. The female (top section) clips over the top. They can also slide on if necessary.

			Product Name				Project Name	Creation Date	Page	Scale	Projection
	<b>Install</b>	Never strike extrusion directly with a hammer or rubber mallet. Use a pine plank between the tool and the extrusion to avoid surface damage or denting.	Ever Art Wood - Kabebari				Rectangle 30x85		6 of 37	1:1	
	<b>End caps</b>	Secure to batten with screw or exterior grade adhesive (Sikaflex).	Approval	Chek	Drawing	Design	Customer	Distributor		Manufacturer	
No.	DATE							<b>covet</b>			

### Kabebari batten detail

**Profile: Rectangle 40x20mm**

Base: 0.403kg/m

Cover: 0.231kg/m

Total: 0.634kg/m

Batten thickness: 1.0mm

End cap thickness: 1.0mm

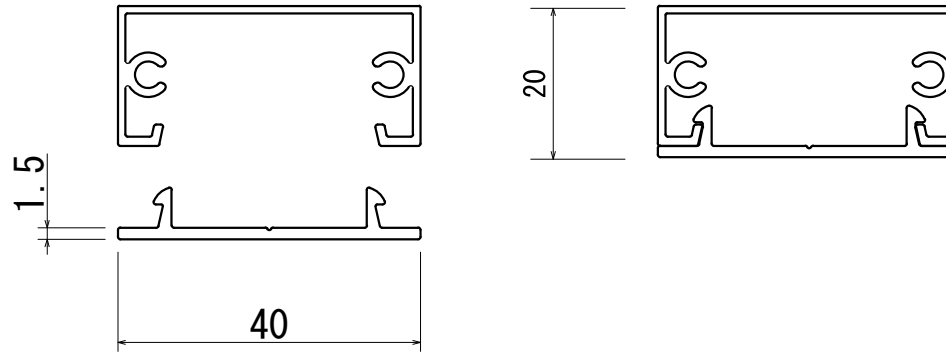



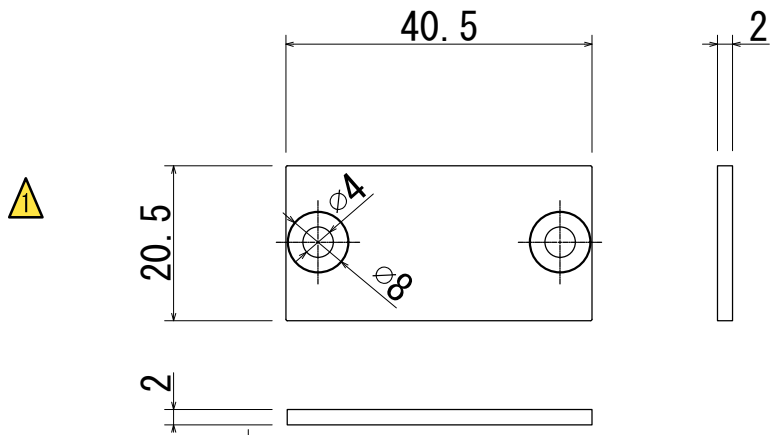

### Endcap detail

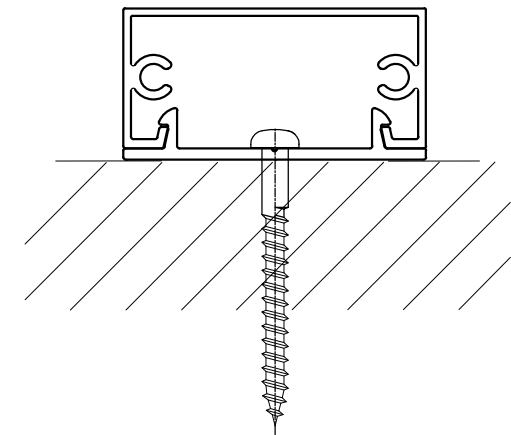

### Installation detail



			Product Name				Project Name	Creation Date	Page	Scale	Projection
	<b>Install</b>	Never strike extrusion directly with a hammer or rubber mallet. Use a pine plank between the tool and the extrusion to avoid surface damage or denting.	Ever Art Wood - Kabebari				Rectangle 40x20		7 of 37	1:1	
	<b>End caps</b>	Screw fix or apply exterior grade adhesive (Sikaflex) to secure cap to batten.	Approval	Chek	Drawing	Design	Customer	Distributor		Manufacturer	
No.	DATE							<b>covet</b>			

### Kabebari batten detail

#### Profile: Rectangle 50x100mm

Base: 0.547kg/m

Cover: 1.258kg/m

Total: 1.805kg/m

Batten thickness: 1.5mm

End cap thickness: 2.0mm

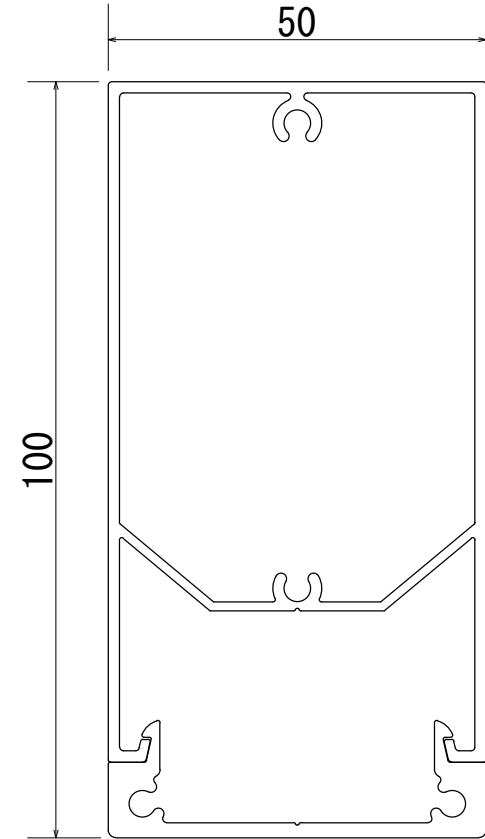
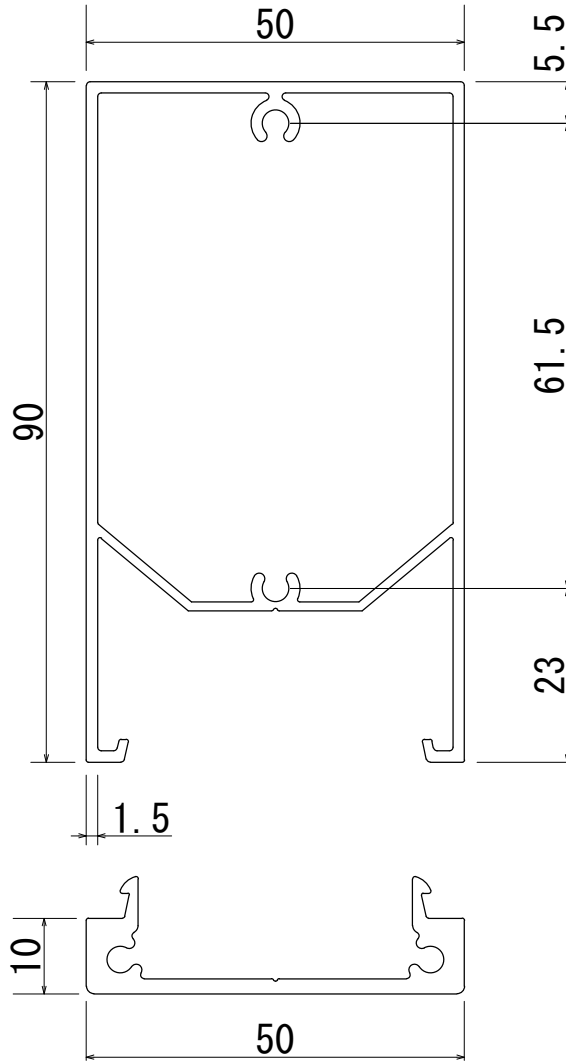

3			Product Name				Project Name	Creation Date	Page	Scale	Projection	
	2	<b>Install</b>	Never strike extrusion directly with a hammer or rubber mallet. Use a pine plank between the tool and the extrusion to avoid surface damage or denting.				Ever Art Wood - Kabebari	Rectangle 50x100		8 of 37	1:1	⊕
1	<b>End caps</b>	Screw fix or apply exterior grade adhesive (Sikaflex) to secure cap to batten.				Approval	Chek	Drawing	Design	Customer	Distributor	Manufacturer
No.	DATE									<b>covet</b>	<b>TAKASHO</b>	





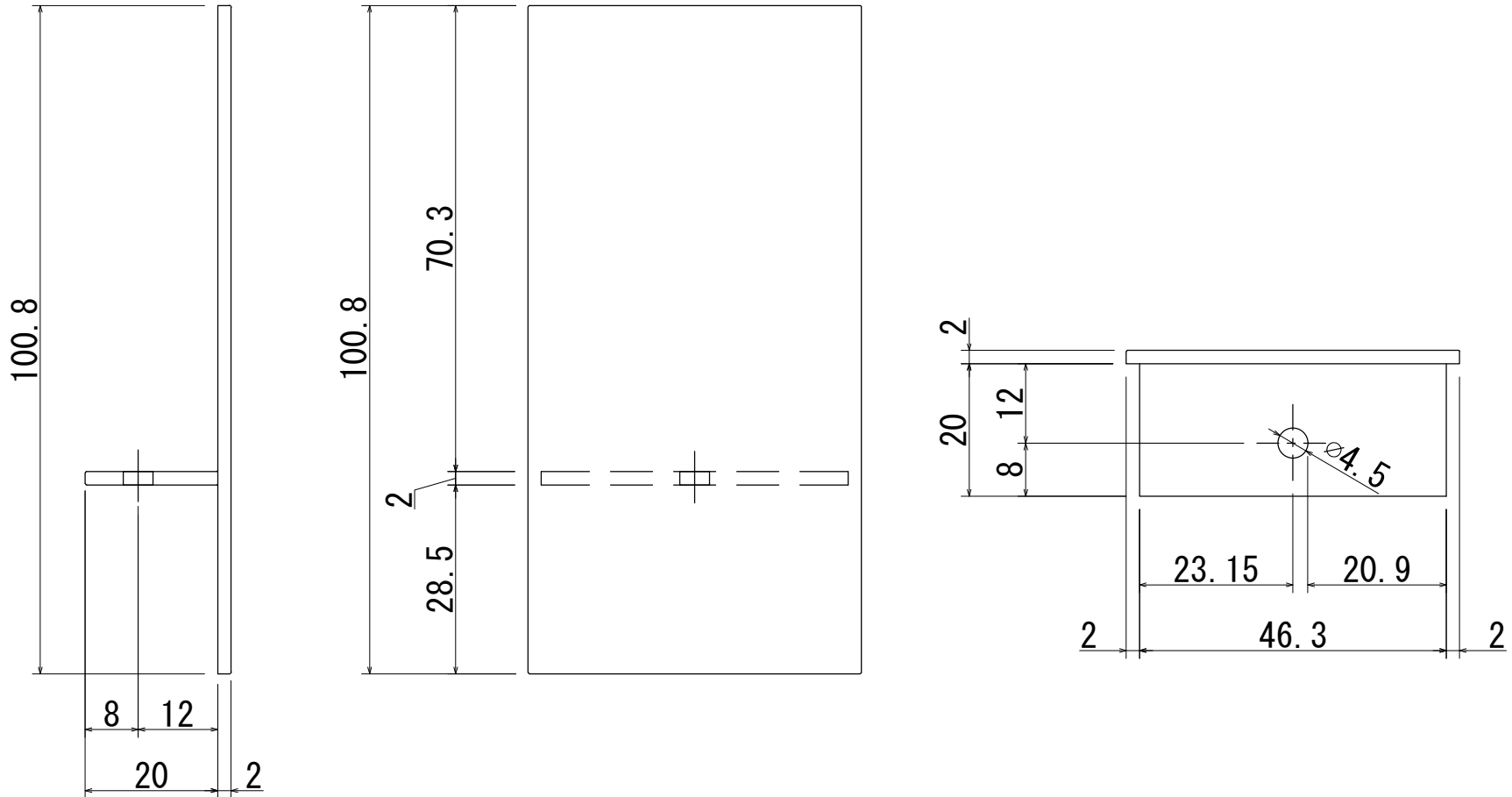

### Kabebari batten detail

Profile: Rectangle 50x100mm

Endcap detail   
Aluminium t=2.0



			Product Name				Project Name	Creation Date	Page	Scale	Projection
	<b>Install</b>	Never strike extrusion directly with a hammer or rubber mallet. Use a pine plank between the tool and the extrusion to avoid surface damage or denting.	Ever Art Wood - Kabebari				Rectangle 50x100		9 of 37	1:1	
	<b>End caps</b>	Screw fix or apply exterior grade adhesive (Sikaflex) to secure cap to batten.	Approval	Chek	Drawing	Design	Customer	Distributor		Manufacturer	
No.	DATE							<b>covet</b>			

### Kabebari batten detail



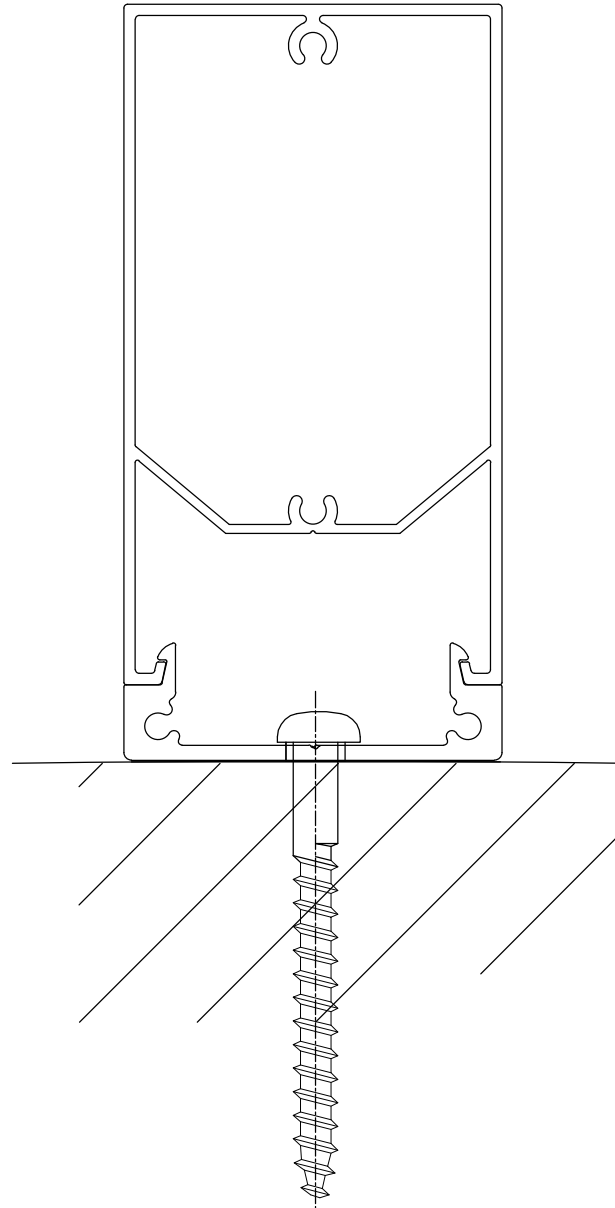

Profile: Rectangle 50x100mm

Installation detail 



### Kabebari Batten Installation Guide

- Aluminium can be damaged if mishandled. Never strike directly with a hammer or rubber mallet. Use a pine plank between the striking rubber mallet and the extrusion to avoid surface damage or denting.
- Cut aluminium with a drop saw using an aluminium blade.
- Always cap ends of extrusions with supplied end caps or a flashing to avoid moisture ingress.
- Plastic end caps must be securely inserted with screws supplied or sikaflex applied to the inside of the extrusion before inserting. This will prevent slippage of the extrusion.
- Metal end caps (painted) must be screwed to the extrusion.
- All end caps can only be applied to straight 90 degree cuts. They cannot be applied to angle end cuts.
- Ensure appropriate screws are used to suit the substrate you are fastening to. It is important to use stainless steel or bi-metal screws for all metal surfaces impacted when fastening (i.e. furring channels, top hats, steel frames). This will prevent galvanic reaction between the screw/substrate and aluminium extrusion.
- Fasten at maximum 1 metre spans. Please contact Covet for further information.
- Always fasten the male (base) section first. The female (top section) clips over the top. They can also slide on if necessary.

			Product Name				Project Name	Creation Date	Page	Scale	Projection
	<b>Install</b>	Never strike extrusion directly with a hammer or rubber mallet. Use a pine plank between the tool and the extrusion to avoid surface damage or denting.	Ever Art Wood - Kabebari				Rectangle 50x100		10 of 37	1:1	
	<b>End caps</b>	Screw fix or apply exterior grade adhesive (Sikaflex) to secure cap to batten.	Approval	Chek	Drawing	Design	Customer	Distributor		Manufacturer	
No.	DATE							<b>covet</b>			

# Kabebari batten detail

Profile: Rectangle 50x100mm

## Aluminium Endcap Installation detail ⚠

①

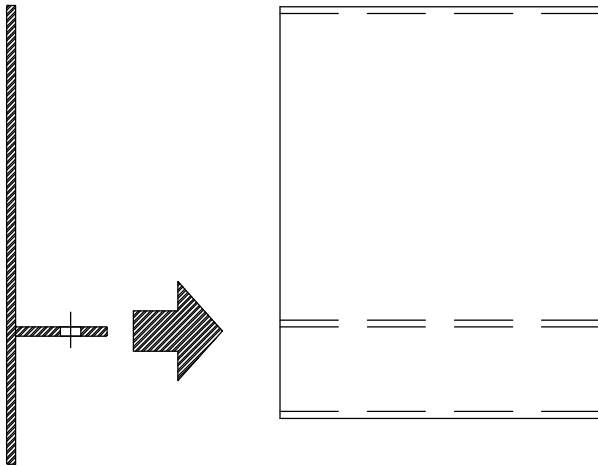

②

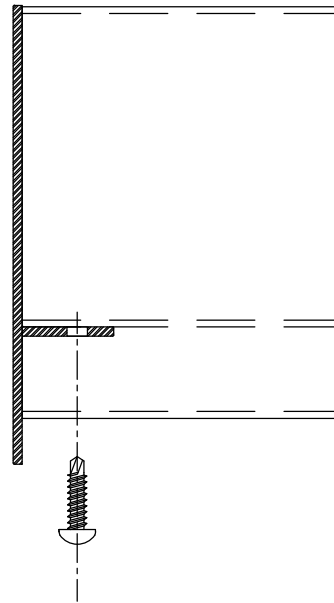

③

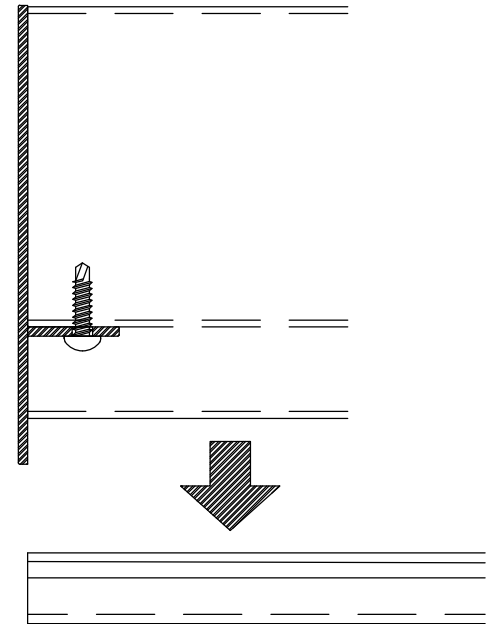

③			Product Name				Project Name	Creation Date	Page	Scale	Projection
②	<b>Install</b>	Never strike extrusion directly with a hammer or rubber mallet. Use a pine plank between the tool and the extrusion to avoid surface damage or denting.	Ever Art Wood - Kabebari				Rectangle 50x100		11 of 37	1:1	⊕
①	<b>End caps</b>	Screw fix or apply exterior grade adhesive (Sikaflex) to secure cap to batten.	Approval	Chek	Drawing	Design	Customer	Distributor		Manufacturer	
No.	DATE							<b>covet</b>			

### Kabebari batten detail

**Profile: Rectangle 50x150mm**

Base: 0.547kg/m

Cover: 2.007kg/m

Total: 2.554kg/m

Batten thickness: 2.0mm (top) 1.5mm (bottom)

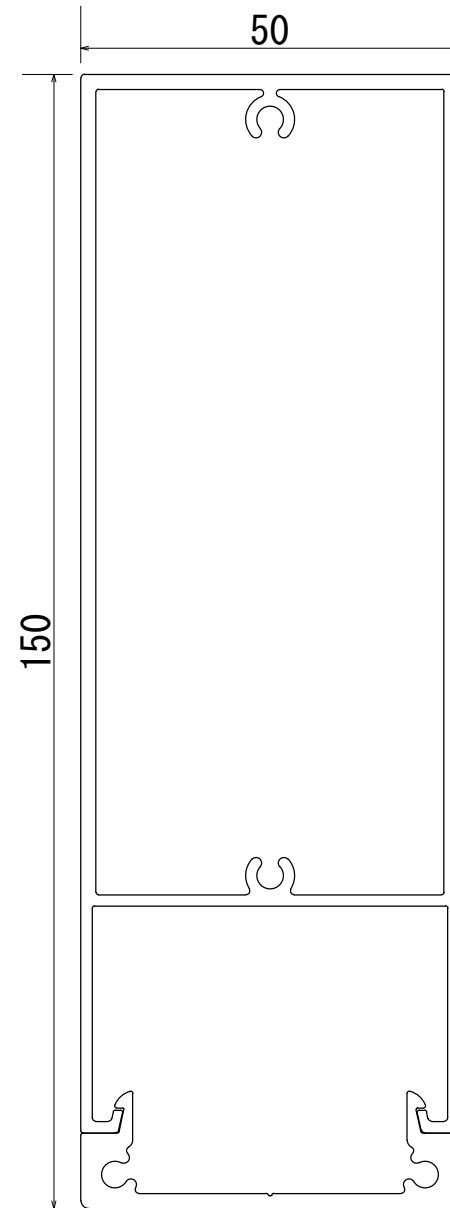
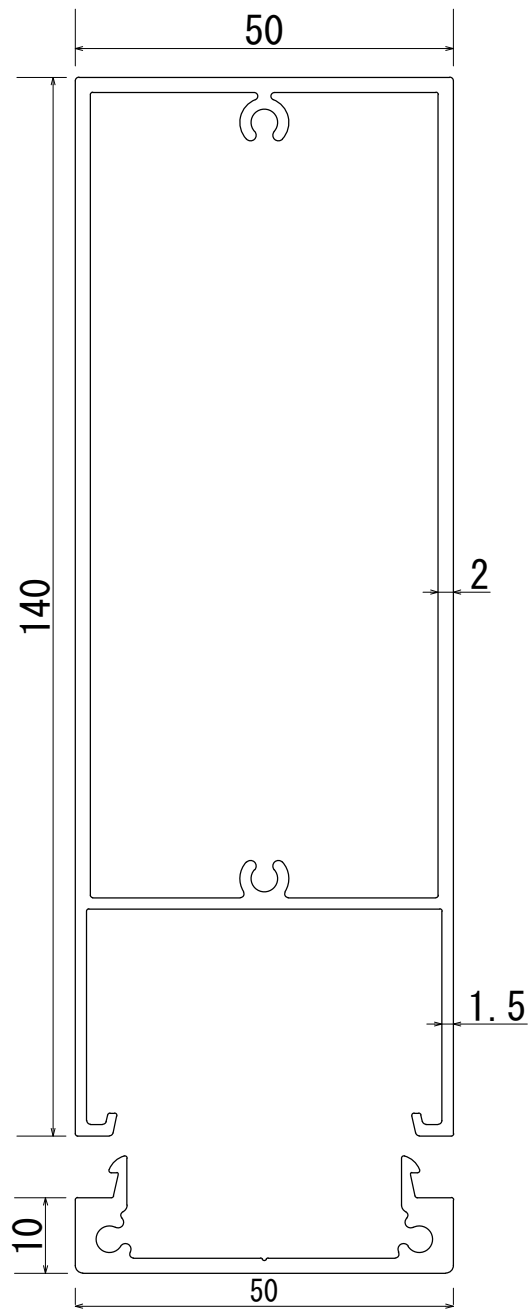

3			Product Name				Project Name	Creation Date	Page	Scale	Projection
	2	<b>Install</b>	Never strike extrusion directly with a hammer or rubber mallet. Use a pine plank between the tool and the extrusion to avoid surface damage or denting.		Ever Art Wood - Kabebari		Rectangle 50x150		12 of 37	1:1	☉
1	<b>End caps</b>	Apply exterior grade adhesive (Sikaflex) to secure cap to batten.		Approval	Chek	Drawing	Design	Customer	Distributor	Manufacturer	
No.	DATE								<b>covet</b>		



### Kabebari batten detail

**Profile: Square 30x30mm**

Base: 0.348kg/m

Cover: 0.347kg/m

Total: 0.695kg/m

Batten thickness: 1.2mm

End cap thickness: 3.0mm

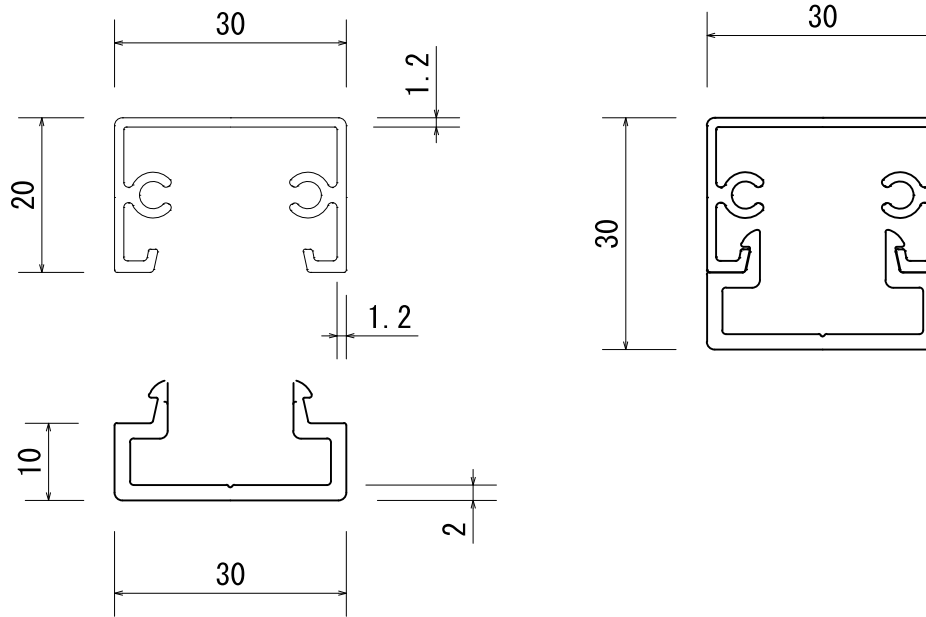

### Endcap detail

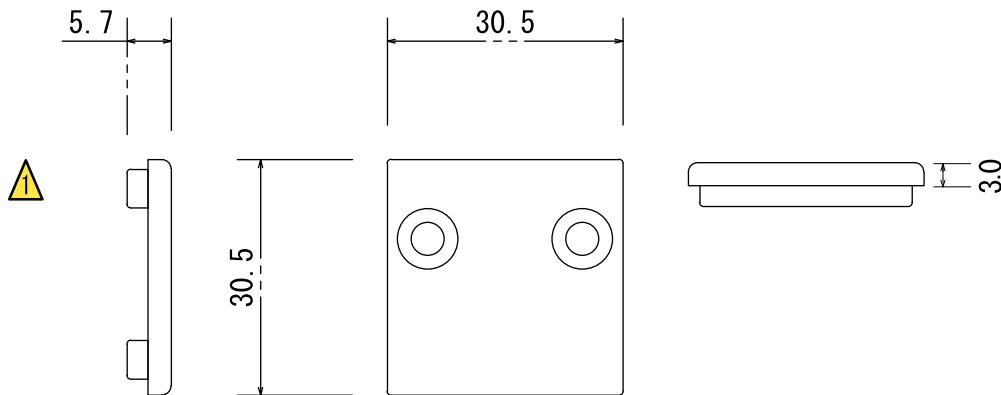

### Installation detail

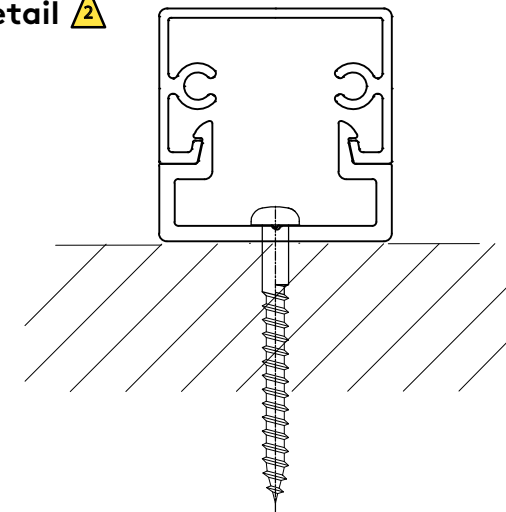

			Product Name				Project Name	Creation Date	Page	Scale	Projection
	<b>Install</b>	Never strike extrusion directly with a hammer or rubber mallet. Use a pine plank between the tool and the extrusion to avoid surface damage or denting.	Ever Art Wood - Kabebari				Square 30x30		15 of 37	1:1	
	<b>End caps</b>	Secure to batten with screw or exterior grade adhesive (Sikaflex).	Approval	Chek	Drawing	Design	Customer	Distributor		Manufacturer	
No.	DATE							<b>covet</b>			

### Kabebari batten detail

#### Profile: Square 40x40mm

Base: 0.489kg/m

Cover: 0.207kg/m

Total: 0.696kg/m

Batten thickness: 1.2mm

End cap thickness: 2.0mm

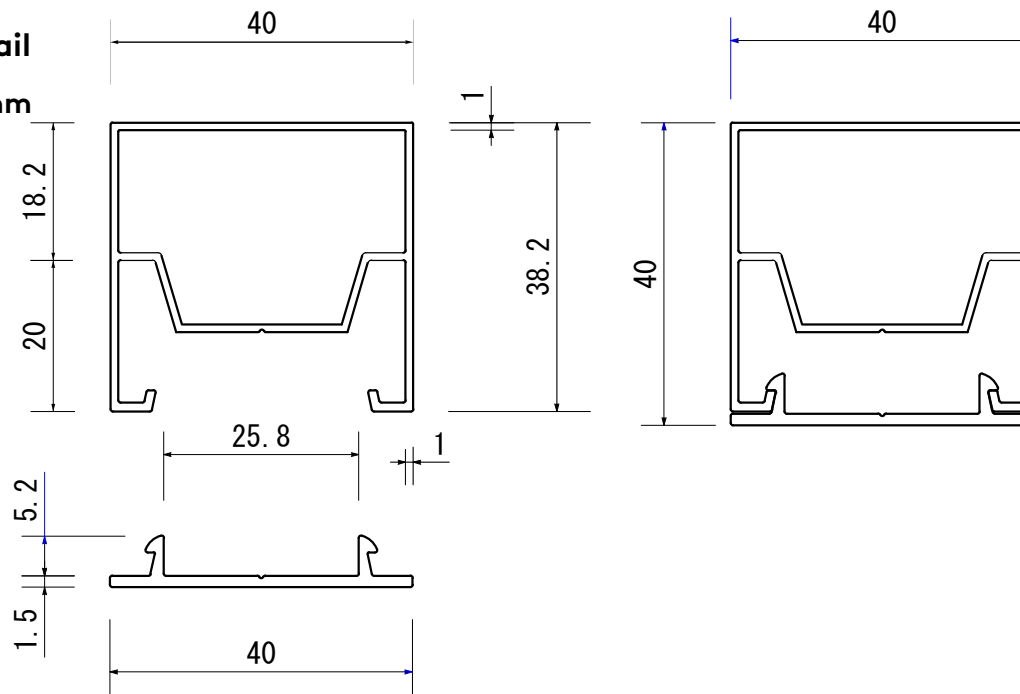

### Endcap detail

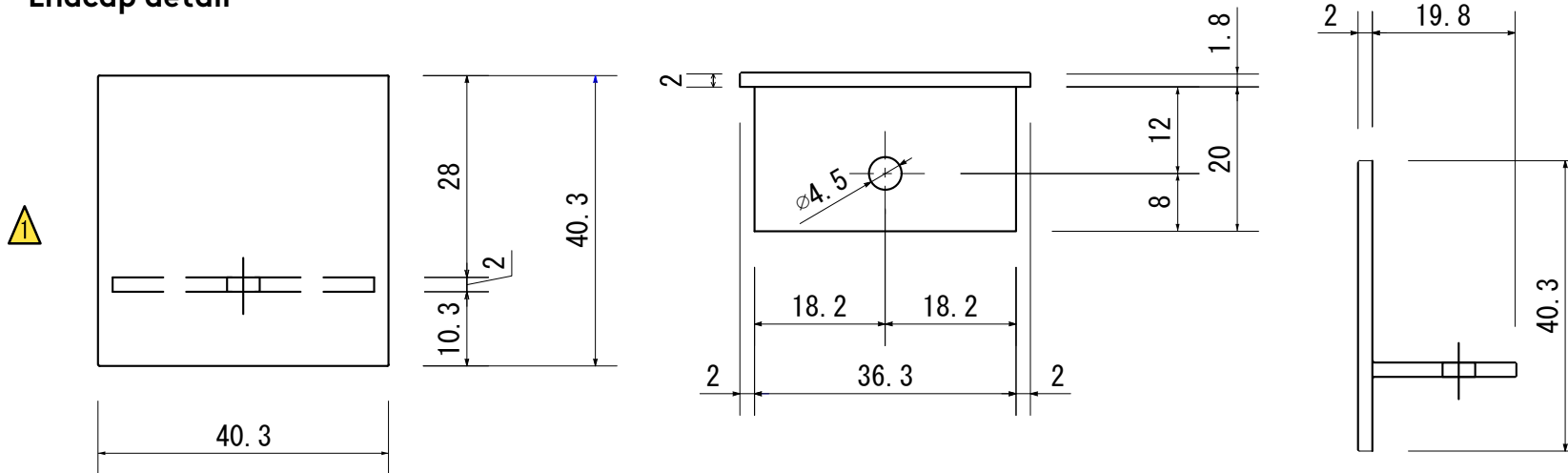

3		Product Name				Project Name	Creation Date	Page	Scale	Projection
2		Ever Art Wood - Kabebari				Square 40x40		16 of 37	1:1	First Angle
1		End caps				Customer	Distributor		Manufacturer	
Install		Never strike extrusion directly with a hammer or rubber mallet. Use a pine plank between the tool and the extrusion to avoid surface damage or denting.					covet		Takasho	
End caps		Secure to batten with screw or exterior grade adhesive (Sikaflex).								
No.	DATE	Approval	Chek	Drawing	Design					

# Kabebari batten detail

Profile: Square 40x40mm

## Installation detail

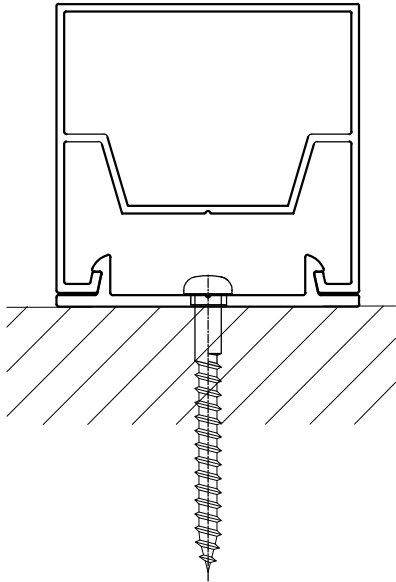

## Installation detail - Endcap

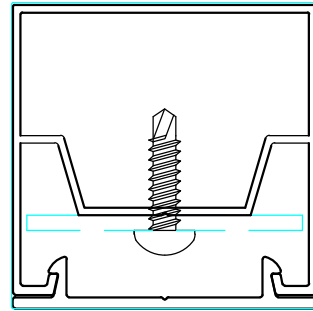

## Kabebari Batten Installation Guide

- Aluminium can be damaged if mishandled. Never strike directly with a hammer or rubber mallet. Use a pine plank between the striking rubber mallet and the extrusion to avoid surface damage or denting.
- Cut aluminium with a drop saw using an aluminium blade.
- Always cap ends of extrusions with supplied end caps or a flashing to avoid moisture ingress.
- Plastic end caps must be securely inserted with screws supplied or sikaflex applied to the inside of the extrusion before inserting. This will prevent slippage of the extrusion.
- Metal end caps (painted) must be screwed to the extrusion.
- All end caps can only be applied to straight 90 degree cuts. They cannot be applied to angle end cuts.
- Ensure appropriate screws are used to suit the substrate you are fastening to. It is important to use stainless steel or bi-metal screws for all metal surfaces impacted when fastening (i.e. furring channels, top hats, steel frames). This will prevent galvanic reaction between the screw/substrate and aluminium extrusion.
- Fasten at maximum 1 metre spans. Please contact Covet for further information.
- Always fasten the male (base) section first. The female (top section) clips over the top. They can also slide on if necessary.

3			Product Name				Project Name	Creation Date	Page	Scale	Projection
2	<b>Install</b>	Never strike extrusion directly with a hammer or rubber mallet. Use a pine plank between the tool and the extrusion to avoid surface damage or denting.	Ever Art Wood - Kabebari				Square 40x40		17 of 37	1:1	
1	<b>End caps</b>	Secure to batten with screw or exterior grade adhesive (Sikaflex).	Approval	Chek	Drawing	Design	Customer	Distributor		Manufacturer	
No.	DATE							<b>covet</b>			



### Kabebari batten detail

**Profile: Square 50x50mm**

Base: 0.547kg/m

Cover: 0.853kg/m

Total: 1.400kg/m

Batten thickness: 1.5mm

End cap thickness: 2.0mm

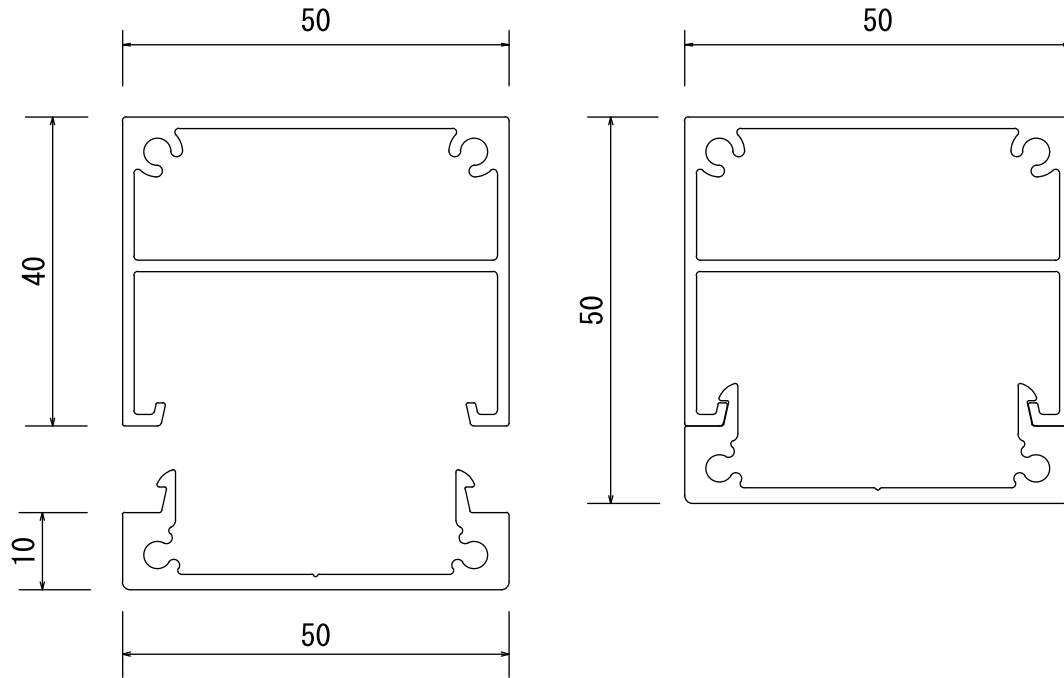

### Endcap detail

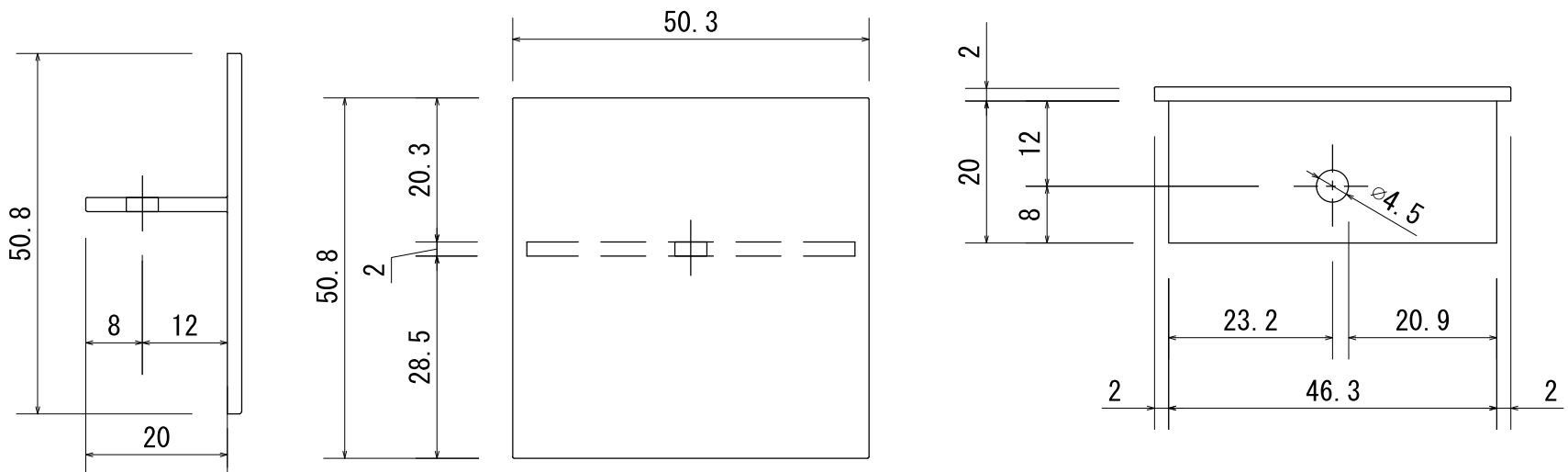

3			Product Name				Project Name	Creation Date	Page	Scale	Projection
2	<b>Install</b>	Never strike extrusion directly with a hammer or rubber mallet. Use a pine plank between the tool and the extrusion to avoid surface damage or denting.	Ever Art Wood - Kabebari				Square 50x50		18 of 37	1:1	⊕
1	<b>End caps</b>	Secure to batten with screw or exterior grade adhesive (Sikaflex).	Approval	Chek	Drawing	Design	Customer	Distributor		Manufacturer	
No.	DATE							<b>covet</b>			

## Kabebari batten detail



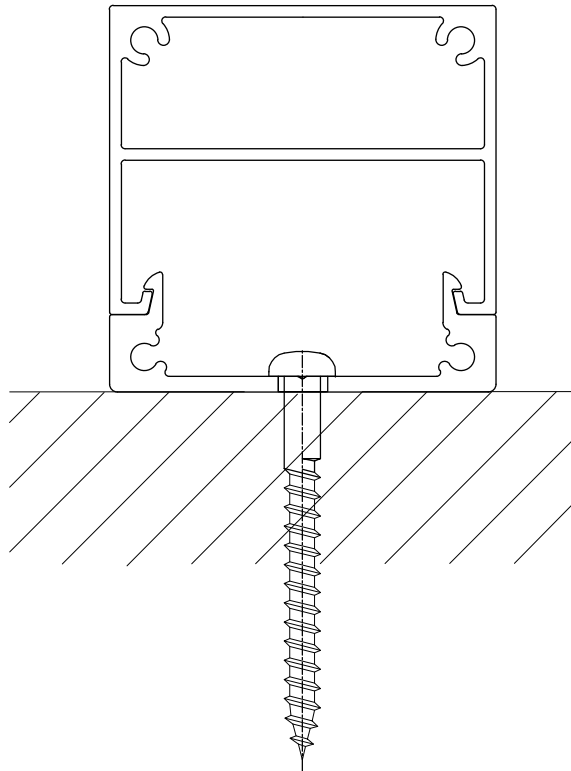
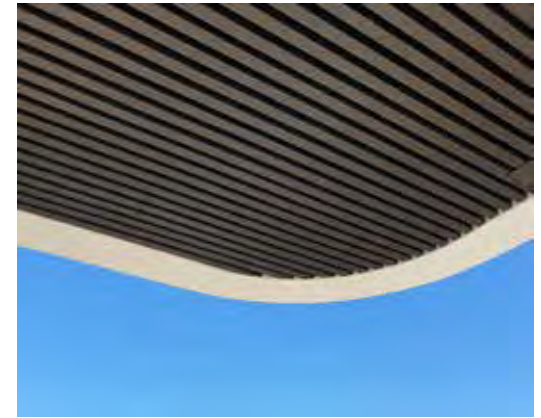

Profile: Square 50x50mm

### Installation detail



### Kabebari Batten Installation Guide

- Aluminium can be damaged if mishandled. Never strike directly with a hammer or rubber mallet. Use a pine plank between the striking rubber mallet and the extrusion to avoid surface damage or denting.
- Cut aluminium with a drop saw using an aluminium blade.
- Always cap ends of extrusions with supplied end caps or a flashing to avoid moisture ingress.
- Plastic end caps must be securely inserted with screws supplied or sikaflex applied to the inside of the extrusion before inserting. This will prevent slippage of the extrusion.
- Metal end caps (painted) must be screwed to the extrusion.
- All end caps can only be applied to straight 90 degree cuts. They cannot be applied to angle end cuts.
- Ensure appropriate screws are used to suit the substrate you are fastening to. It is important to use stainless steel or bi-metal screws for all metal surfaces impacted when fastening (i.e. furring channels, top hats, steel frames). This will prevent galvanic reaction between the screw/substrate and aluminium extrusion.
- Fasten at maximum 1 metre spans. Please contact Covet for further information.
- Always fasten the male (base) section first. The female (top section) clips over the top. They can also slide on if necessary.

			Product Name				Project Name	Creation Date	Page	Scale	Projection
	<b>Install</b>	Never strike extrusion directly with a hammer or rubber mallet. Use a pine plank between the tool and the extrusion to avoid surface damage or denting.	Ever Art Wood - Kabebari				Square 50x50		19 of 37	1:1	
	<b>End caps</b>	Secure to batten with screw or exterior grade adhesive (Sikaflex).	Approval	Chek	Drawing	Design	Customer	Distributor		Manufacturer	
No.	DATE							<b>covet</b>			

### Kabebari batten detail

**Profile: Oki 100x100mm**

Base: 0.692kg/m

Cover: 1.342kg/m

Total: 2.034kg/m

Batten thickness: 1.2mm

End cap thickness: 3.0mm

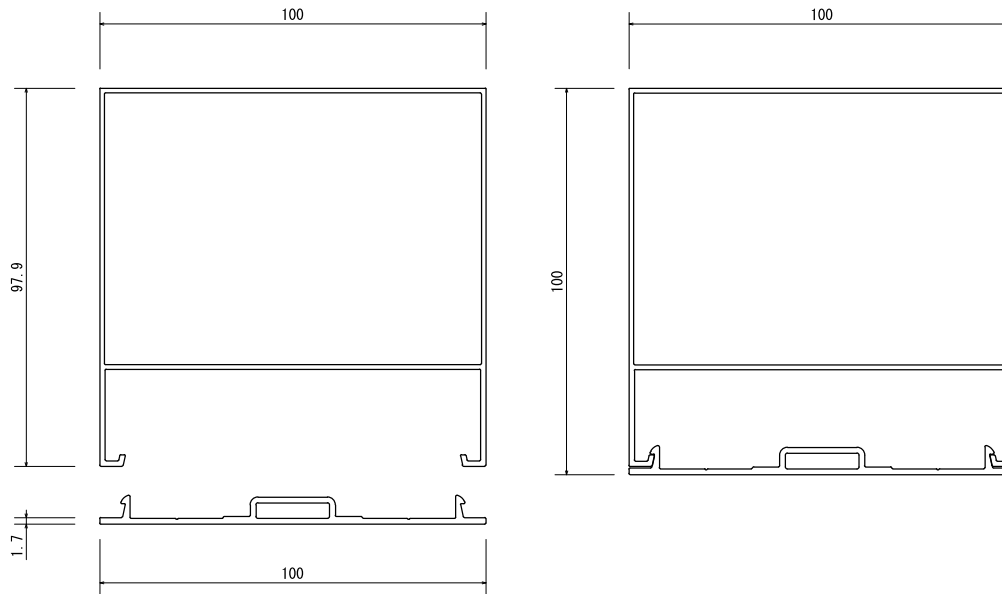

### Endcap detail

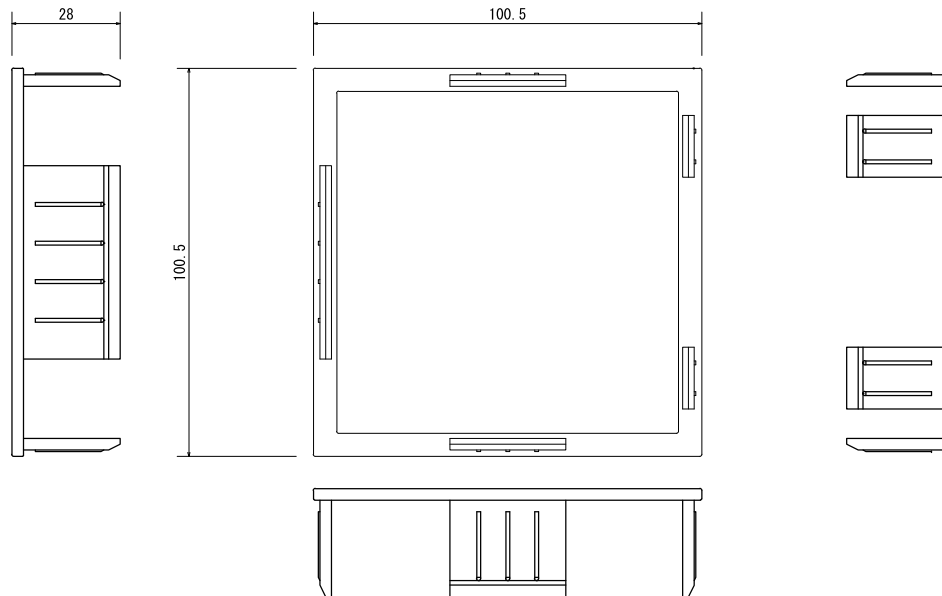

3	<b>End caps</b>	End caps available in plastic or aluminium.	Product Name				Project Name	Creation Date	Page	Scale	Projection
	<b>Install</b>	Never strike extrusion directly with a hammer or rubber mallet. Use a pine plank between the tool and the extrusion to avoid surface damage or denting.	Ever Art Wood - Kabebari				Oki 100x100		20 of 37	1:2	⊕
1	<b>End caps</b>	Secure to batten with screw or exterior grade adhesive (Sikaflex).	Approval	Chek	Drawing	Design	Customer	Distributor		Manufacturer	
No.	DATE							<b>covet</b>		<b>TAKASHO</b>	

### Kabebari batten detail



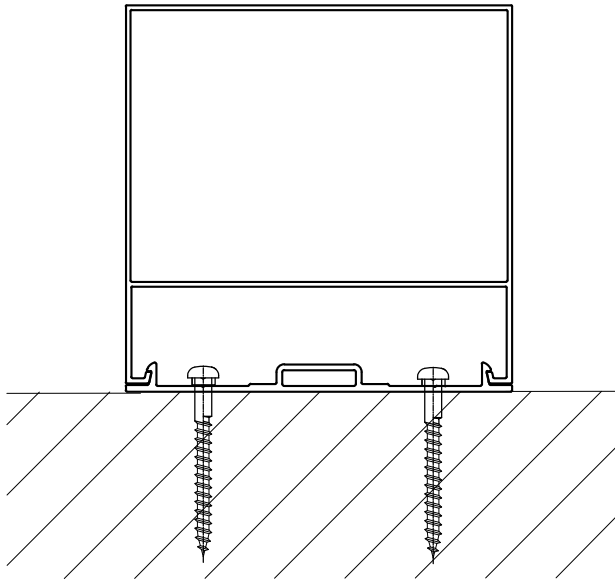

Profile: Oki 100x100mm

Installation detail 



### Kabebari Batten Installation Guide

- Aluminium can be damaged if mishandled. Never strike directly with a hammer or rubber mallet. Use a pine plank between the striking rubber mallet and the extrusion to avoid surface damage or denting.
- Cut aluminium with a drop saw using an aluminium blade.
- Always cap ends of extrusions with supplied end caps or a flashing to avoid moisture ingress.
- Plastic end caps must be securely inserted with screws supplied or sikafelx applied to the inside of the extrusion before inserting. This will prevent slippage of the extrusion.
- Metal end caps (painted) must be screwed to the extrusion.
- All end caps can only be applied to straight 90 degree cuts. They cannot be applied to angle end cuts.
- Ensure appropriate screws are used to suit the substrate you are fastening to. It is important to use stainless steel or bi-metal screws for all metal surfaces impacted when fastening (i.e. furring channels, top hats, steel frames). This will prevent galvanic reaction between the screw/substrate and aluminium extrusion.
- Fasten at maximum 1 metre spans. Please contact Covet for further information.
- Always fasten the male (base) section first. The female (top section) clips over the top. They can also slide on if necessary.

	<b>End caps</b>	End caps available in plastic or aluminium.	Product Name				Project Name	Creation Date	Page	Scale	Projection
	<b>Install</b>	Never strike extrusion directly with a hammer or rubber mallet. Use a pine plank between the tool and the extrusion to avoid surface damage or denting.	Ever Art Wood - Kabebari				Oki 100x100		21 of 37	1:2	
	<b>End caps</b>	Secure to batten with screw or exterior grade adhesive (Sikaflex).	Approval	Chek	Drawing	Design	Customer	Distributor		Manufacturer	
No.	DATE							<b>covet</b>			

### Kabebari batten detail

#### Profile: Plank 100x12mm

Base: 0.692kg/m

Cover: 0.417kg/m

Total: 1.109kg/m

Batten thickness: 1.0mm

End cap thickness: 2.0mm

Standard lengths: 4000, 6100mm.

Note: Longest full piece is 5700mm.

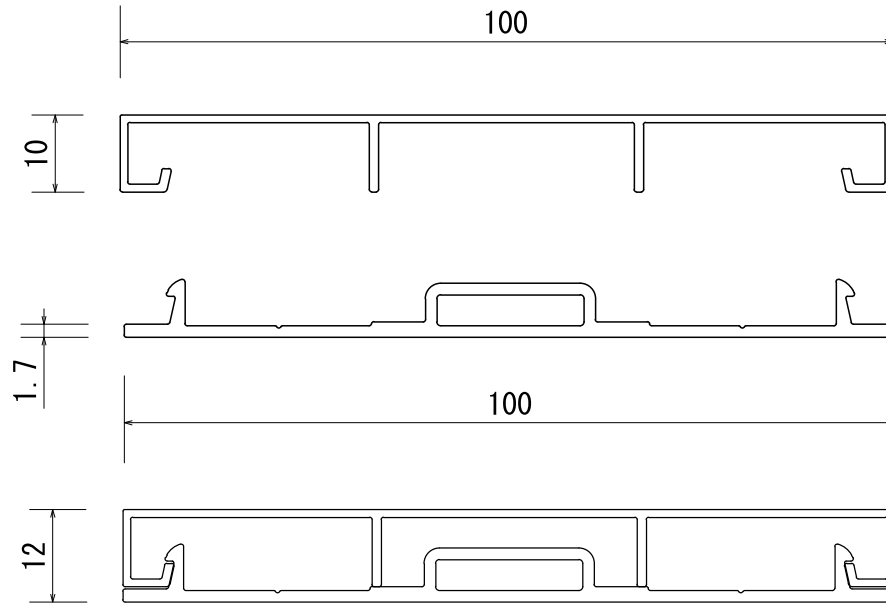



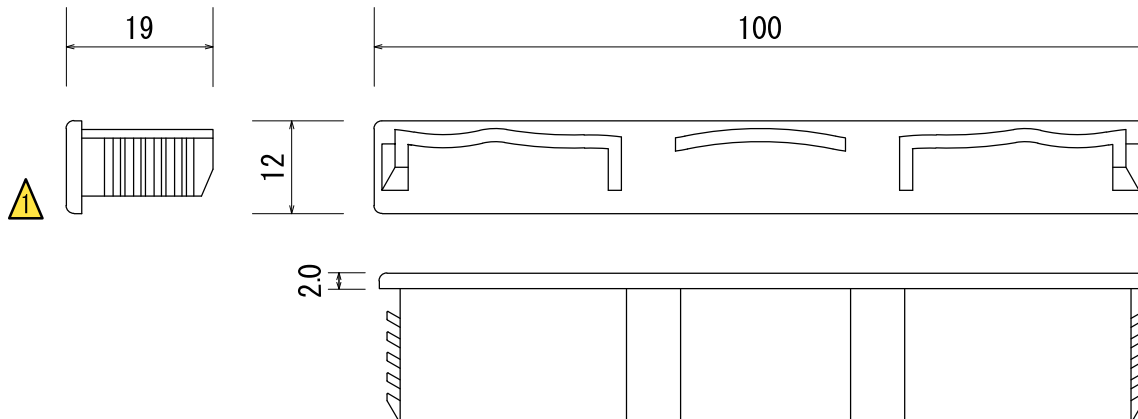

### Endcap detail

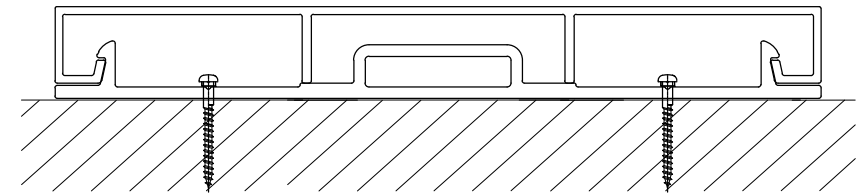

### Installation detail



Not to scale

	<b>Install</b>	Ensure there is a 1mm gap between the base male sections when installing. Insufficient spacing will result in difficulty attaching female sections.	Product Name				Project Name	Creation Date	Page	Scale	Projection
	<b>Install</b>	Never strike extrusion directly with a hammer or rubber mallet. Use a pine plank between the tool and the extrusion to avoid surface damage or denting.	Ever Art Wood - Kabebari				Plank 100x12		22 of 37	1:1	
	<b>End caps</b>	Apply exterior grade adhesive (Sikaflex) to secure cap to batten.	Approval	Chek	Drawing	Design	Customer	Distributor		Manufacturer	
No.	DATE							<b>covet</b>			

### Kabebari batten detail

**Profile: Nami Plank 100x12mm**

Base: 0.692kg/m

Cover: 0.458kg/m

Total: 1.15kg/m

Batten thickness: 1.2mm

End cap thickness: 2.0mm

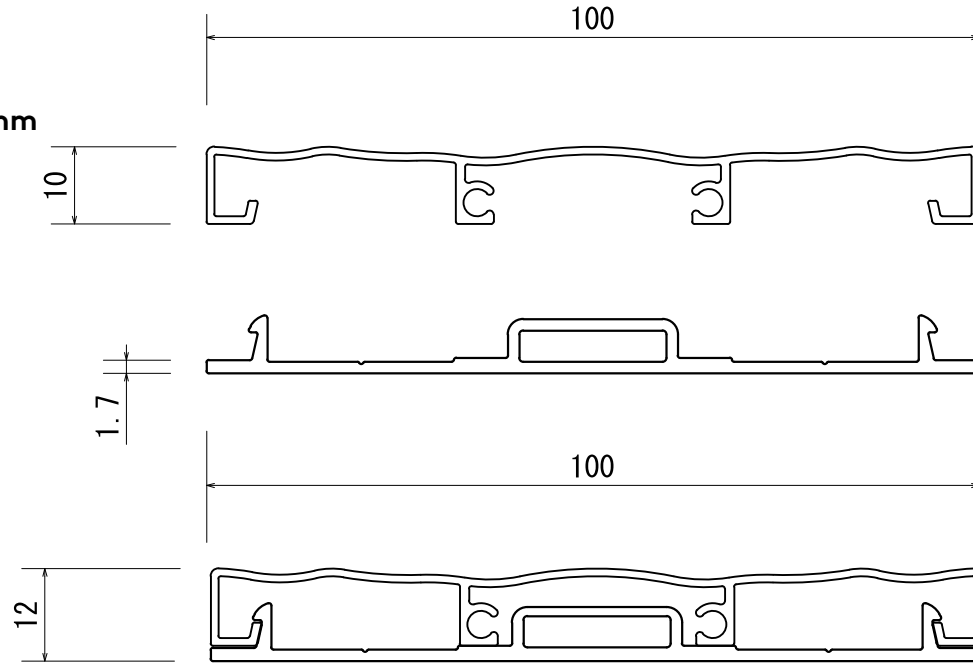



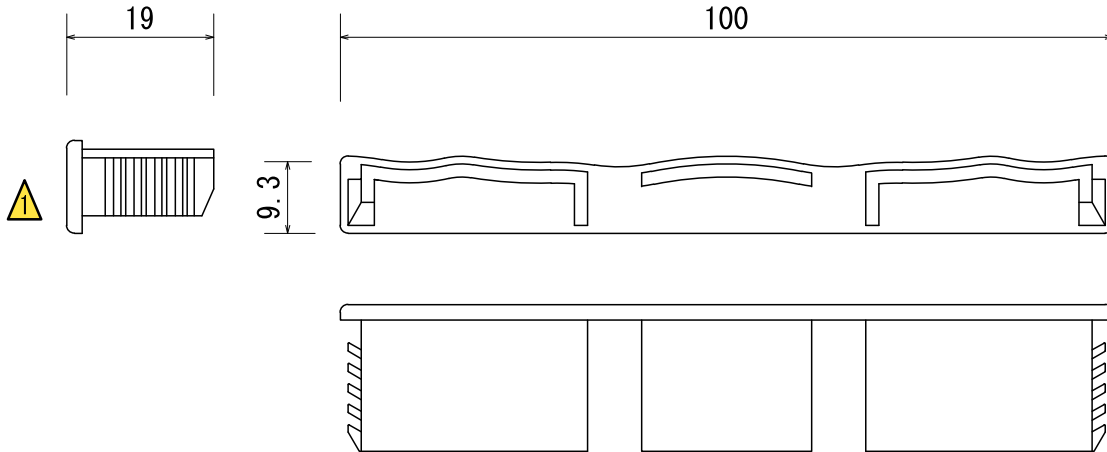

### Endcap detail

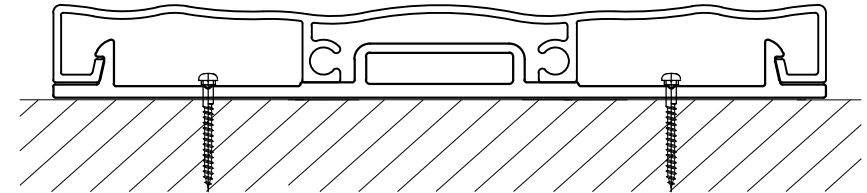

### Installation detail







Not to scale

	<b>Install</b>	Ensure there is a 1mm gap between the base male sections when installing. Insufficient spacing will result in difficulty attaching female sections.	Product Name				Project Name	Creation Date	Page	Scale	Projection
		<b>Install</b>	Never strike extrusion directly with a hammer or rubber mallet. Use a pine plank between the tool and the extrusion to avoid surface damage or denting.	Ever Art Wood - Kabebari				Nami Plank 100x12		23 of 37	1:1
	<b>End caps</b>	Apply exterior grade adhesive (Sikaflex) to secure cap to batten.	Approval	Chek	Drawing	Design	Customer	Distributor		Manufacturer	
No.	DATE							<b>covet</b>			

## Kabebari Batten Installation Guide

- Aluminium can be damaged if mishandled. Never strike directly with a hammer or rubber mallet. Use a pine plank between the striking rubber mallet and the extrusion to avoid surface damage or denting.
- Cut aluminium with a drop saw using an aluminium blade.
- Always cap ends of extrusions with supplied end caps or a flashing to avoid moisture ingress.
- Plastic end caps must be securely inserted with screws supplied or sikafelx applied to the inside of the extrusion before inserting. This will prevent slippage of the extrusion.
- All end caps can only be applied to straight 90 degree cuts. They cannot be applied to angle end cuts.
- Ensure appropriate screws are used to suit the substrate you are fastening to. It is important to use stainless steel or bi-metal screws for all metal surfaces impacted when fastening (i.e. furring channels, top hats, steel frames). This will prevent galvanic reaction between the screw/substrate and aluminium extrusion.
- Fasten at maximum 1 metre spans. Please contact Covet for further information.
- Always fasten the male (base) section first. The female (top section) clips over the top. They can also slide on if necessary.
- When butting together 12x100 planks ensure there is a 1mm gap between the base male sections. Failure to allow sufficient spacing will result in difficulty attaching female sections.

	<b>Install</b>	Ensure there is a 1mm gap between the base male sections when installing. Insufficient spacing will result in difficulty attaching female sections.	Product Name				Project Name	Creation Date	Page	Scale	Projection
	<b>Install</b>	Never strike extrusion directly with a hammer or rubber mallet. Use a pine plank between the tool and the extrusion to avoid surface damage or denting.	Ever Art Wood - Kabebari				Plank & Nami Plank 100x12		24 of 37	1:1	
	<b>End caps</b>	Apply exterior grade adhesive (Sikaflex) to secure cap to batten.	Approval	Chek	Drawing	Design	Customer	Distributor		Manufacturer	
No.	DATE							<b>covet</b>			

### Kabebari batten detail

#### Profile: Round Single 22x18mm

Base: 0.084kg/m

Cover: 0.15kg/m

Total: 0.234kg/m

\*End cover: 0.167kg/m

Batten thickness: 1.0mm

End cap thickness: 2.5mm

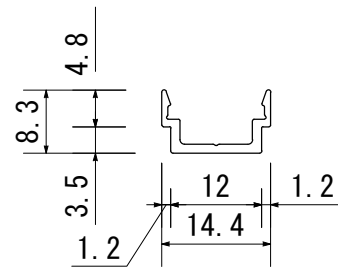
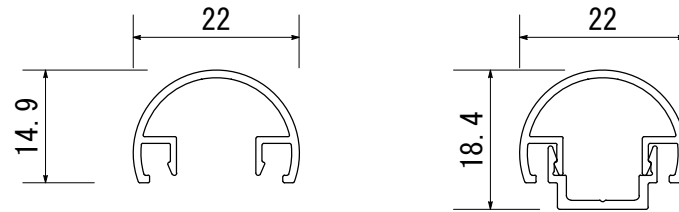
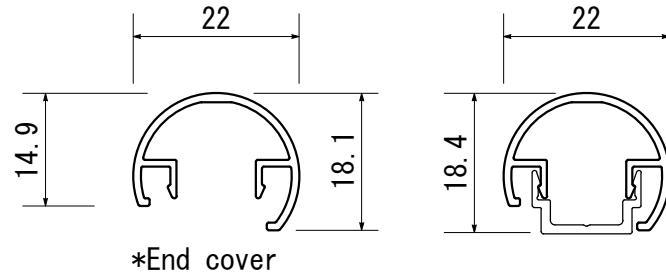



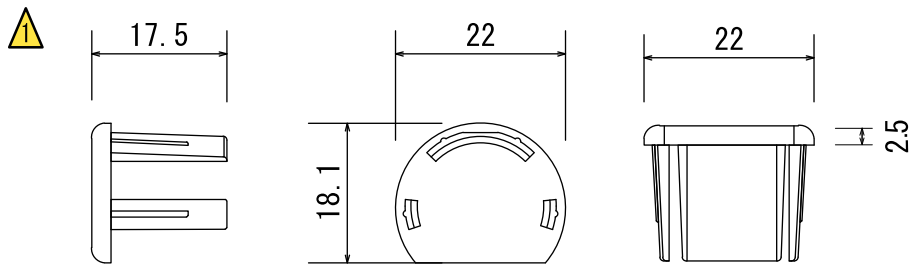

### Endcap detail

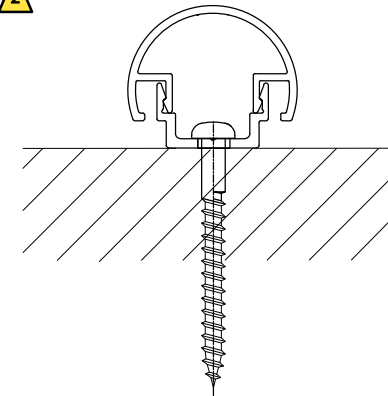

### Installation detail



			Product Name				Project Name	Creation Date	Page	Scale	Projection
	<b>Install</b>	Never strike extrusion directly with a hammer or rubber mallet. Use a pine plank between the tool and the extrusion to avoid surface damage or denting.	Ever Art Wood - Kabebari				Round Single 22x18		25 of 37	1:1	
	<b>End caps</b>	Screw fix or apply exterior grade adhesive (Sikaflex) to secure cap to batten.	Approval	Chek	Drawing	Design	Customer	Distributor		Manufacturer	
No.	DATE							<b>covet</b>			



### Kabebari batten detail

#### Profile: Round Double 44.5x18mm

Base: 0.166kg/m

Cover: 0.15kg/m x2

Total: 0.466kg/m

\*End cover: 0.167kg/m

Batten thickness: 1.0mm

End cap thickness: 2.6mm

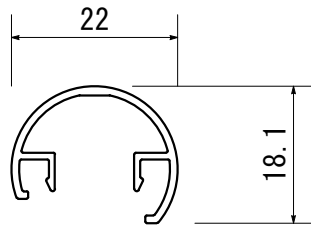

\*End cover

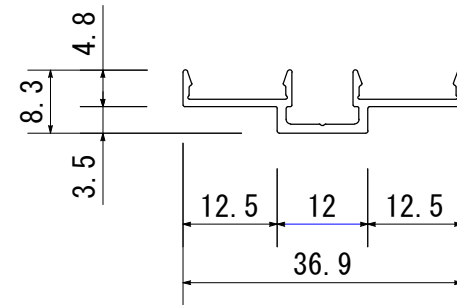
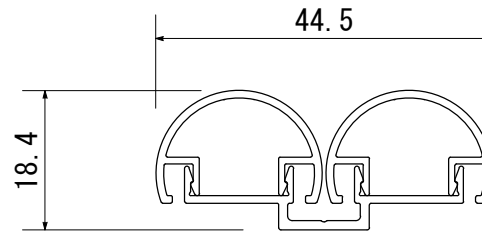
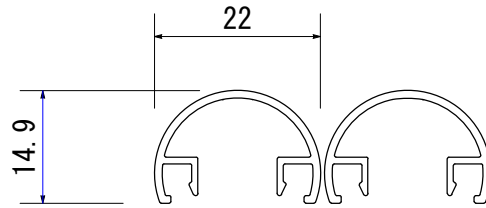
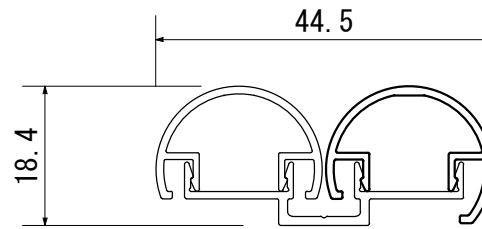

### Endcap detail

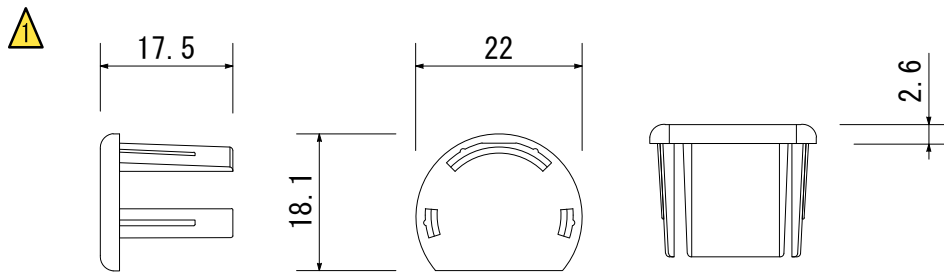

3			Product Name				Project Name	Creation Date	Page	Scale	Projection
	2	<b>Install</b>	Never strike extrusion directly with a hammer or rubber mallet. Use a pine plank between the tool and the extrusion to avoid surface damage or denting.	Ever Art Wood - Kabebari				Round Double 44.5x18		26 of 37	1:1
1	<b>End caps</b>	Screw fix or apply exterior grade adhesive (Sikaflex) to secure cap to batten.	Approval	Chek	Drawing	Design	Customer	Distributor		Manufacturer	
No.	DATE							<b>covet</b>			

## Kabebari batten detail



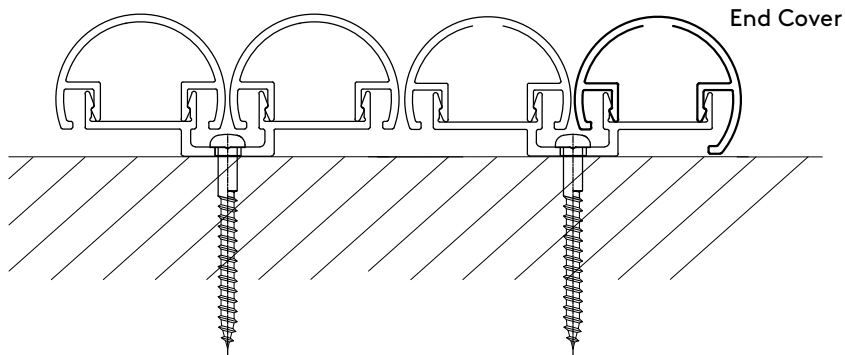

Profile: Round Double 44.5x18mm

### Installation detail



## Kabebari Batten Installation Guide

- Aluminium can be damaged if mishandled. Never strike directly with a hammer or rubber mallet. Use a pine plank between the striking rubber mallet and the extrusion to avoid surface damage or denting.
- Cut aluminium with a drop saw using an aluminium blade.
- Always cap ends of extrusions with supplied end caps or a flashing to avoid moisture ingress.
- Plastic end caps must be securely inserted with screws supplied or sikaflex applied to the inside of the extrusion before inserting. This will prevent slippage of the extrusion.
- Metal end caps (painted) must be screwed to the extrusion.
- All end caps can only be applied to straight 90 degree cuts. They cannot be applied to angle end cuts.
- Ensure appropriate screws are used to suit the substrate you are fastening to. It is important to use stainless steel or bi-metal screws for all metal surfaces impacted when fastening (i.e. furring channels, top hats, steel frames). This will prevent galvanic reaction between the screw/substrate and aluminium extrusion.
- Fasten at maximum 1 metre spans. Please contact Covet for further information.
- Always fasten the male (base) section first. The female (top section) clips over the top. They can also slide on if necessary.

			Product Name				Project Name	Creation Date	Page	Scale	Projection
	<b>Install</b>	Never strike extrusion directly with a hammer or rubber mallet. Use a pine plank between the tool and the extrusion to avoid surface damage or denting.	Ever Art Wood - Kabebari				Round Double 44.5x18		27 of 37	1:1	
	<b>End caps</b>	Screw fix or apply exterior grade adhesive (Sikaflex) to secure cap to batten.	Approval	Chek	Drawing	Design	Customer	Distributor		Manufacturer	
No.	DATE							<b>covet</b>			

### Kabebari batten detail

**Profile: Slimline 30x13mm**

Base: 0.108kg/m

Cover: 0.173kg/m

Total: 0.281kg/m

\*End Cover: 0.209kg/m Batten

thickness: 1.0mm

End cap thickness: 2.5mm

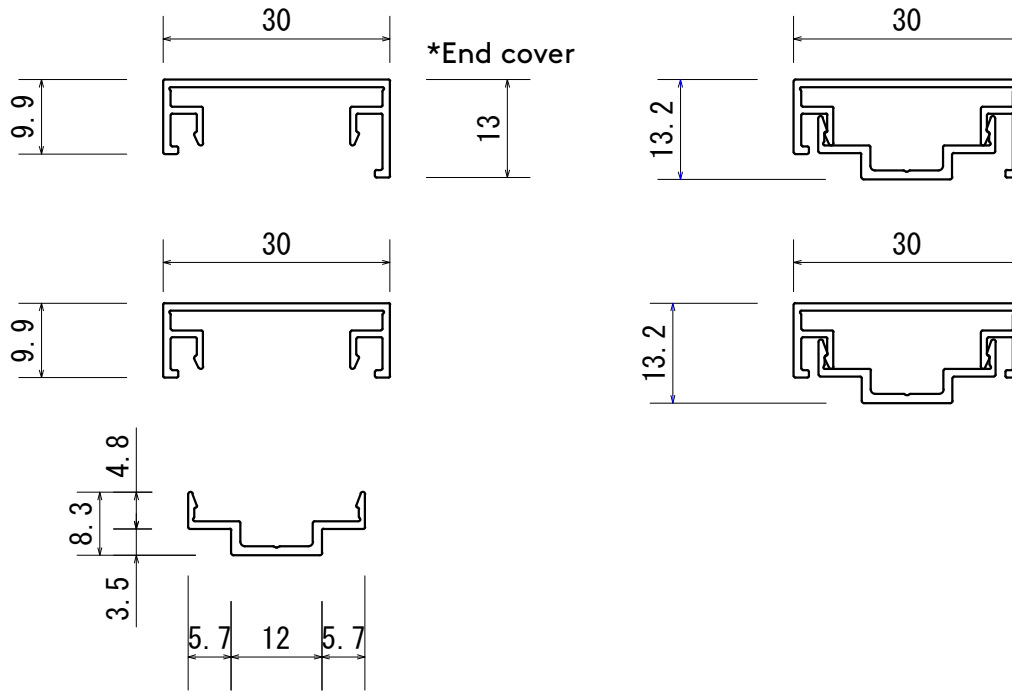

### Endcap detail

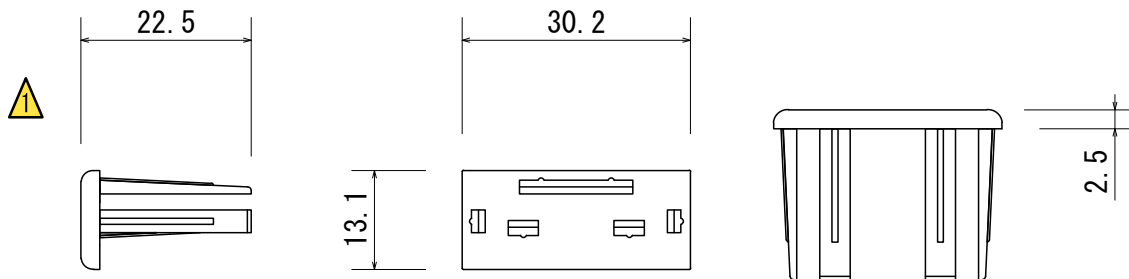

### Installation detail

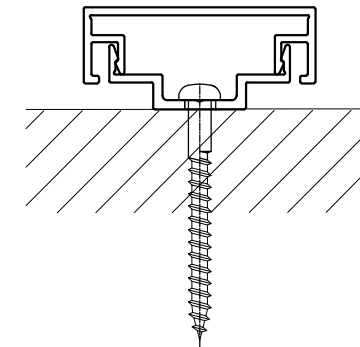

			Product Name				Project Name	Creation Date	Page	Scale	Projection
	<b>Install</b>	Never strike extrusion directly with a hammer or rubber mallet. Use a pine plank between the tool and the extrusion to avoid surface damage or denting.	Ever Art Wood - Kabebari				Slimline 30x13mm		28 of 37	1:1	
	<b>End caps</b>	Screw fix or apply exterior grade adhesive (Sikaflex) to secure cap to batten.	Approval	Chek	Drawing	Design	Customer	Distributor		Manufacturer	
No.	DATE							<b>covet</b>			

## Kabebari Batten Installation Guide

- Aluminium can be damaged if mishandled. Never strike directly with a hammer or rubber mallet. Use a pine plank between the striking rubber mallet and the extrusion to avoid surface damage or denting.
- Cut aluminium with a drop saw using an aluminium blade.
- Always cap ends of extrusions with supplied end caps or a flashing to avoid moisture ingress.
- Plastic end caps must be securely inserted with screws supplied or sikafelx applied to the inside of the extrusion before inserting. This will prevent slippage of the extrusion.
- Metal end caps (painted) must be screwed to the extrusion.
- All end caps can only be applied to straight 90 degree cuts. They cannot be applied to angle end cuts.
- Ensure appropriate screws are used to suit the substrate you are fastening to. It is important to use stainless steel or bi-metal screws for all metal surfaces impacted when fastening (i.e. furring channels, top hats, steel frames). This will prevent galvanic reaction between the screw/substrate and aluminium extrusion.
- Fasten at maximum 1 metre spans. Please contact Covet for further information.
- Always fasten the male (base) section first. The female (top section) clips over the top. They can also slide on if necessary.



3			Product Name				Project Name	Creation Date	Page	Scale	Projection
2	<b>Install</b>	Never strike extrusion directly with a hammer or rubber mallet. Use a pine plank between the tool and the extrusion to avoid surface damage or denting.	Ever Art Wood - Kabebari				Slimline 30x13mm		29 of 37	1:1	
1	<b>End caps</b>	Screw fix or apply exterior grade adhesive (Sikaflex) to secure cap to batten.	Approval	Chek	Drawing	Design	Customer	Distributor		Manufacturer	
No.	DATE							<b>covet</b>			

### Kabebari batten detail

**Profile: Slimline 30x18mm**

Base: 0.108kg/m

Cover: 0.201kg/m

Total: 0.309kg/m

\*End Cover: 0.209kg/m

Batten thickness: 1.0mm

End cap thickness: 2.5mm

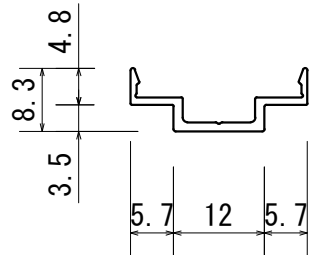
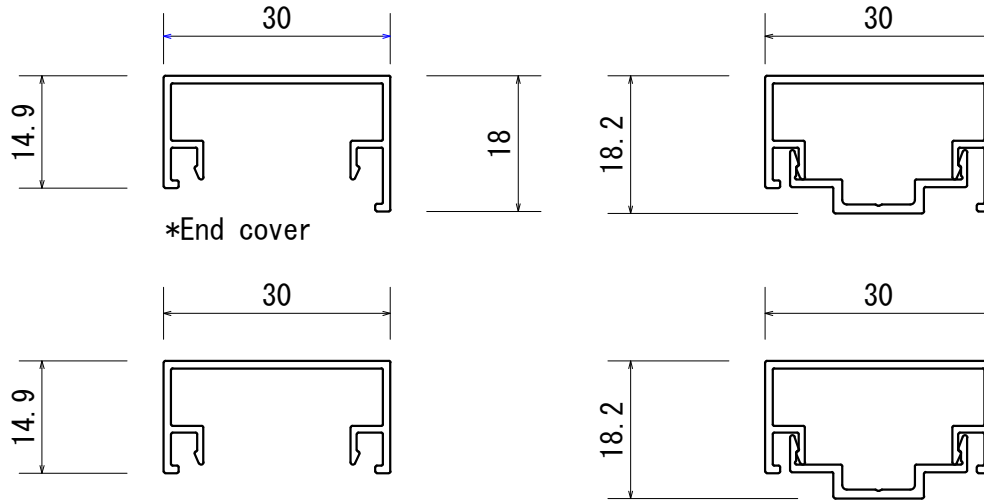



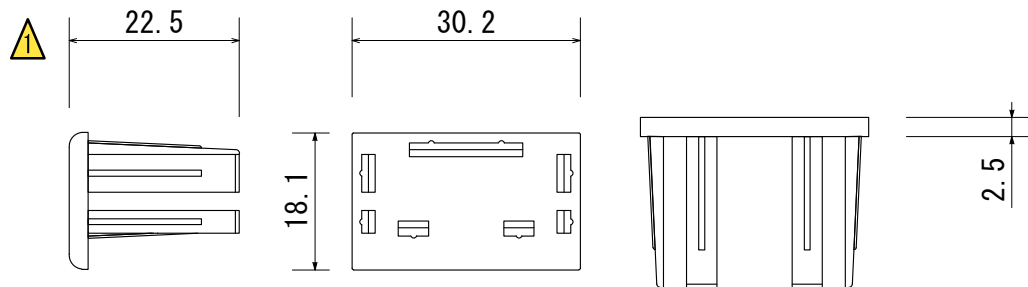

### Endcap detail

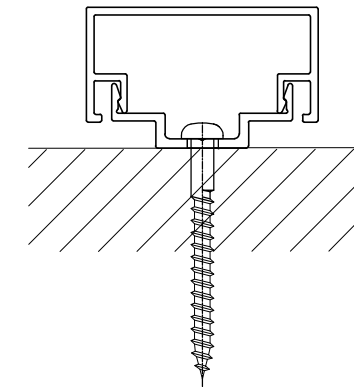

### Installation detail



			Product Name				Project Name	Creation Date	Page	Scale	Projection
	<b>Install</b>	Never strike extrusion directly with a hammer or rubber mallet. Use a pine plank between the tool and the extrusion to avoid surface damage or denting.	Ever Art Wood - Kabebari				Slimline 30x18mm		30 of 37	1:1	
	<b>End caps</b>	Screw fix or apply exterior grade adhesive (Sikaflex) to secure cap to batten.	Approval	Chek	Drawing	Design	Customer	Distributor		Manufacturer	
No.	DATE							<b>covet</b>			

## Kabebari Batten Installation Guide

- Aluminium can be damaged if mishandled. Never strike directly with a hammer or rubber mallet. Use a pine plank between the striking rubber mallet and the extrusion to avoid surface damage or denting.
- Cut aluminium with a drop saw using an aluminium blade.
- Always cap ends of extrusions with supplied end caps or a flashing to avoid moisture ingress.
- Plastic end caps must be securely inserted with screws supplied or sikafelx applied to the inside of the extrusion before inserting. This will prevent slippage of the extrusion.
- Metal end caps (painted) must be screwed to the extrusion.
- All end caps can only be applied to straight 90 degree cuts. They cannot be applied to angle end cuts.
- Ensure appropriate screws are used to suit the substrate you are fastening to. It is important to use stainless steel or bi-metal screws for all metal surfaces impacted when fastening (i.e. furring channels, top hats, steel frames). This will prevent galvanic reaction between the screw/substrate and aluminium extrusion.
- Fasten at maximum 1 metre spans. Please contact Covet for further information.
- Always fasten the male (base) section first. The female (top section) clips over the top. They can also slide on if necessary.



3			Product Name				Project Name	Creation Date	Page	Scale	Projection
2	<b>Install</b>	Never strike extrusion directly with a hammer or rubber mallet. Use a pine plank between the tool and the extrusion to avoid surface damage or denting.	Ever Art Wood - Kabebari				Slimline 30x18mm		31 of 37	1:1	↗
1	<b>End caps</b>	Screw fix or apply exterior grade adhesive (Sikaflex) to secure cap to batten.	Approval	Chek	Drawing	Design	Customer	Distributor		Manufacturer	
No.	DATE							<b>covet</b>			

### Kabebari batten detail

#### Profile: Mikadzuki 44x18mm

Base: 0.166kg/m

Cover: 0.202kg/m

Total: 0.368kg/m

\*End cover: 0.213kg/m

Batten thickness: 1.0mm

End cap thickness: 2.5mm

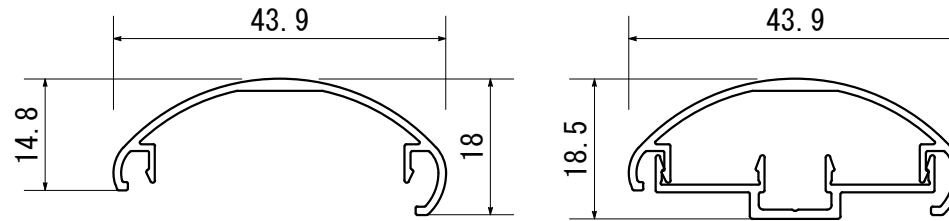

\*End cover

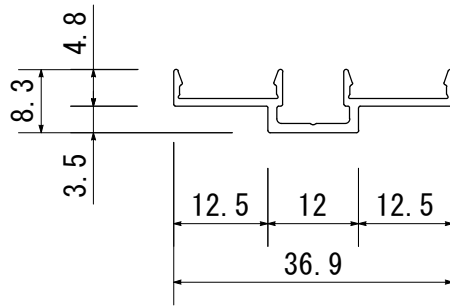
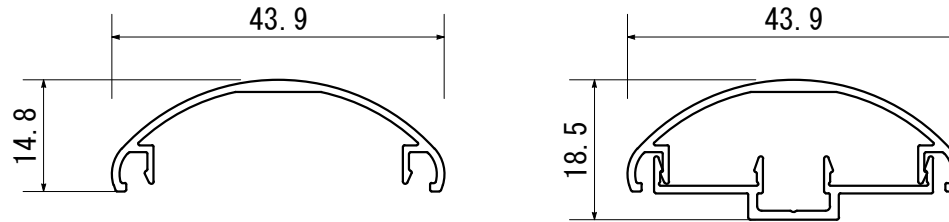



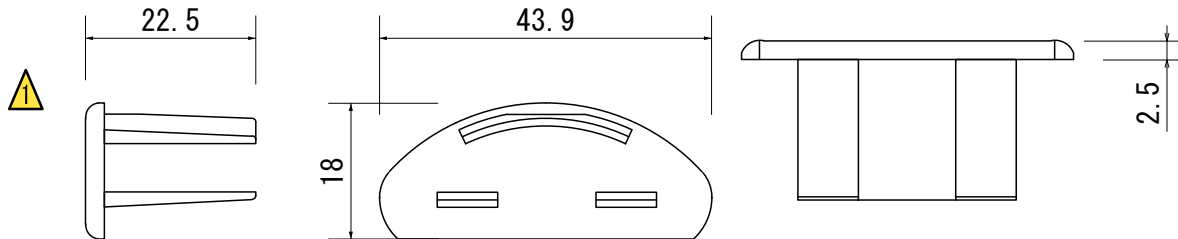

### Endcap detail

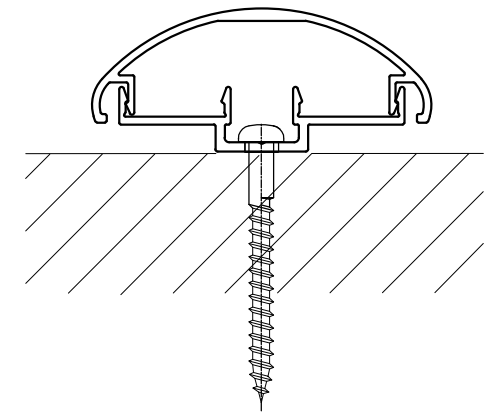

### Installation detail



			Product Name				Project Name	Creation Date	Page	Scale	Projection
	<b>Install</b>	Never strike extrusion directly with a hammer or rubber mallet. Use a pine plank between the tool and the extrusion to avoid surface damage or denting.	Ever Art Wood - Kabebari				Mikadzuki 44x18		32 of 37	1:1	
	<b>End caps</b>	Screw fix or apply exterior grade adhesive (Sikaflex) to secure cap to batten.	Approval	Chek	Drawing	Design	Customer	Distributor		Manufacturer	
No.	DATE							<b>covet</b>			

### Kabebari batten detail

#### Profile: Domu 90x42

Base: 0.576kg/m

Cover: 0.802kg/m

Total: 1.378kg/m

Batten thickness: 1.3mm

End cap thickness: 3.5mm

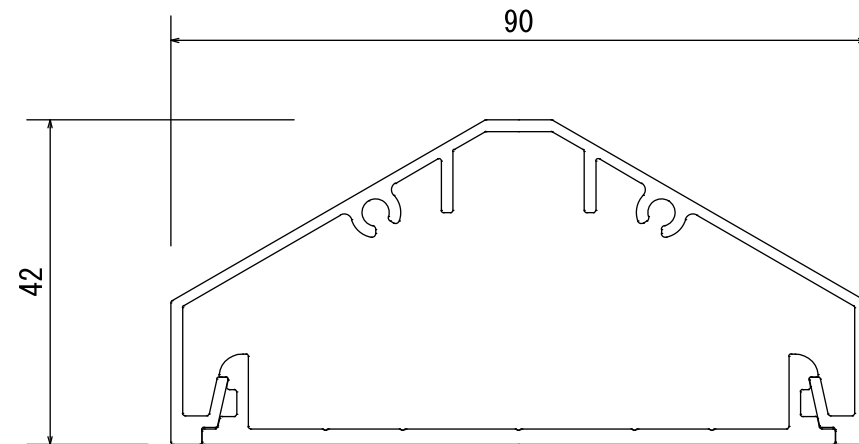
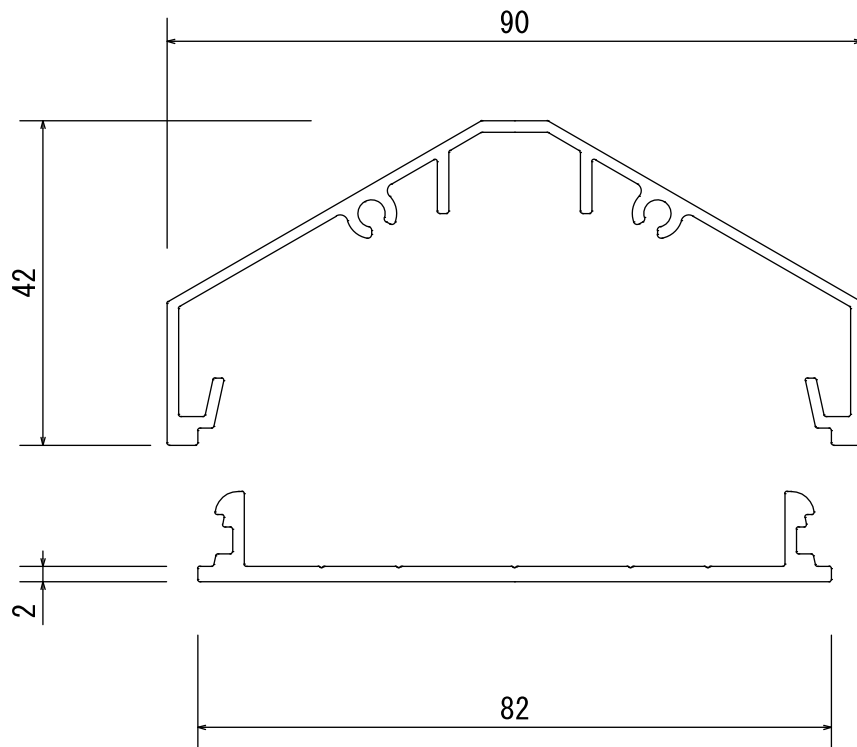

3			Product Name				Project Name	Creation Date	Page	Scale	Projection
2	<b>Install</b>	Never strike extrusion directly with a hammer or rubber mallet. Use a pine plank between the tool and the extrusion to avoid surface damage or denting.	Ever Art Wood - Kabebari				Domu 90x42		33 of 37	1:1	⊕
1	<b>End caps</b>	Screw fix or apply exterior grade adhesive (Sikaflex) to secure cap to batten.	Approval	Chek	Drawing	Design	Customer	Distributor		Manufacturer	
No.	DATE							<b>covet</b>			





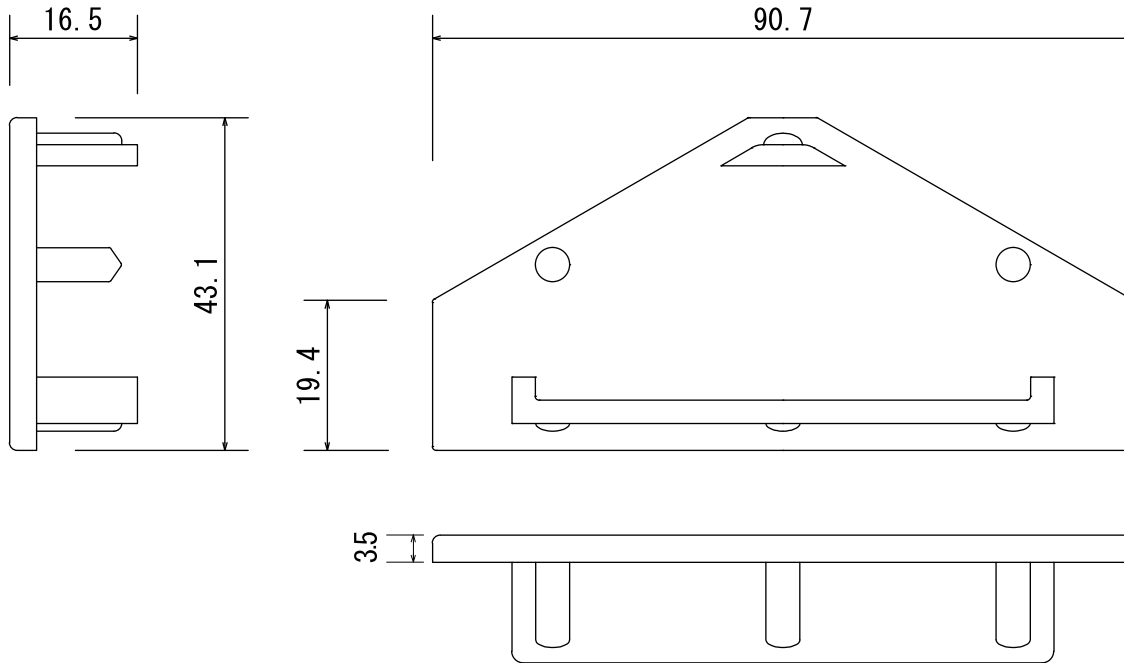

### Kabebari batten detail

Profile: Domu 90x42

### Endcap detail



			Product Name				Project Name	Creation Date	Page	Scale	Projection
	<b>Install</b>	Never strike extrusion directly with a hammer or rubber mallet. Use a pine plank between the tool and the extrusion to avoid surface damage or denting.	Ever Art Wood - Kabebari				Domu 90x42		34 of 37	1:1	
	<b>End caps</b>	Screw fix or apply exterior grade adhesive (Sikaflex) to secure cap to batten.	Approval	Chek	Drawing	Design	Customer	Distributor		Manufacturer	
No.	DATE							<b>covet</b>			

## Kabebari batten detail



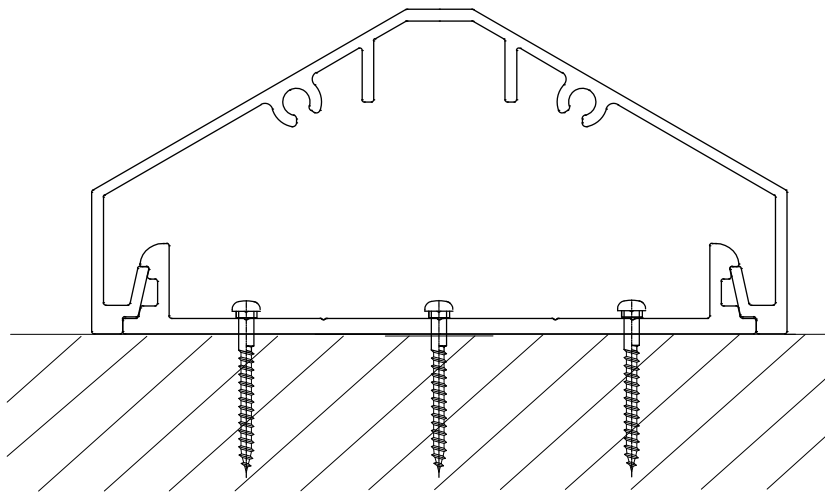

Profile: Domu 90x42

Installation detail 



### Kabebari Batten Installation Guide

- Aluminium can be damaged if mishandled. Never strike directly with a hammer or rubber mallet. Use a pine plank between the striking rubber mallet and the extrusion to avoid surface damage or denting.
- Cut aluminium with a drop saw using an aluminium blade.
- Always cap ends of extrusions with supplied end caps or a flashing to avoid moisture ingress.
- Plastic end caps must be securely inserted with screws supplied or sikaflex applied to the inside of the extrusion before inserting. This will prevent slippage of the extrusion.
- Metal end caps (painted) must be screwed to the extrusion.
- All end caps can only be applied to straight 90 degree cuts. They cannot be applied to angle end cuts.
- Ensure appropriate screws are used to suit the substrate you are fastening to. It is important to use stainless steel or bi-metal screws for all metal surfaces impacted when fastening (i.e. furring channels, top hats, steel frames). This will prevent galvanic reaction between the screw/substrate and aluminium extrusion.
- Fasten at maximum 1 metre spans. Please contact Covet for further information.
- Always fasten the male (base) section first. The female (top section) clips over the top. They can also slide on if necessary.

			Product Name				Project Name	Creation Date	Page	Scale	Projection
	<b>Install</b>	Never strike extrusion directly with a hammer or rubber mallet. Use a pine plank between the tool and the extrusion to avoid surface damage or denting.	Ever Art Wood - Kabebari				Domu 90x42		35 of 37	1:1	
	<b>End caps</b>	Screw fix or apply exterior grade adhesive (Sikaflex) to secure cap to batten.	Approval	Chek	Drawing	Design	Customer	Distributor		Manufacturer	
No.	DATE							<b>covet</b>			

### Kabebari batten detail

#### Profile: Curve 30x18

Base: 0.108kg/m

Cover: 0.194kg/m

Total: 0.302kg/m

\*End cover: 0.203kg/m

Batten thickness: 1.0mm

End cap thickness: 2.5mm

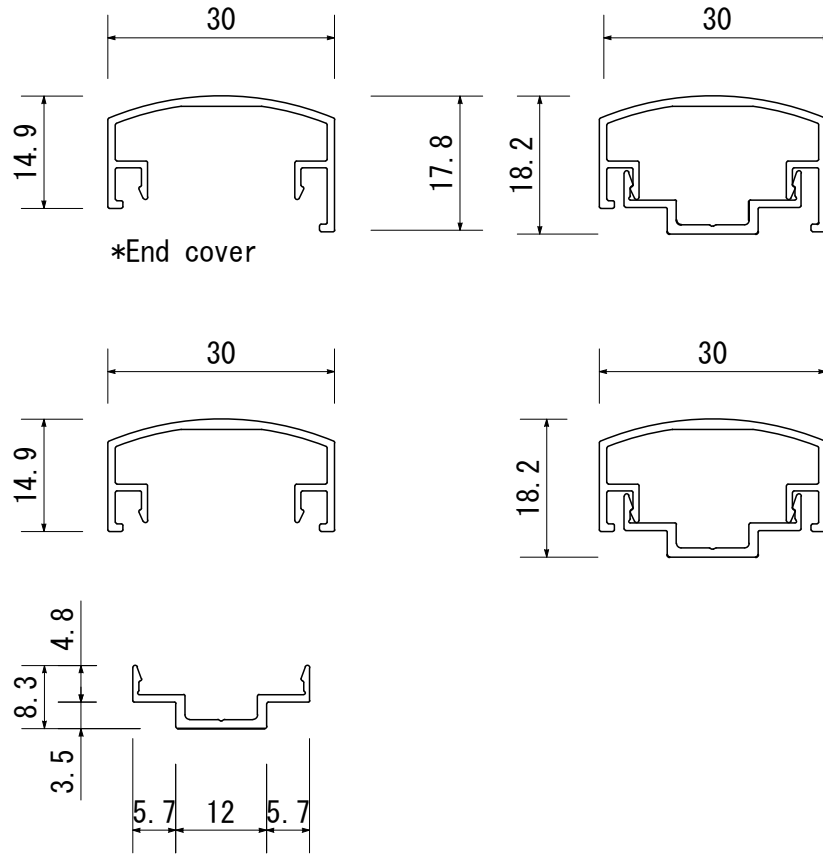

### Endcap detail

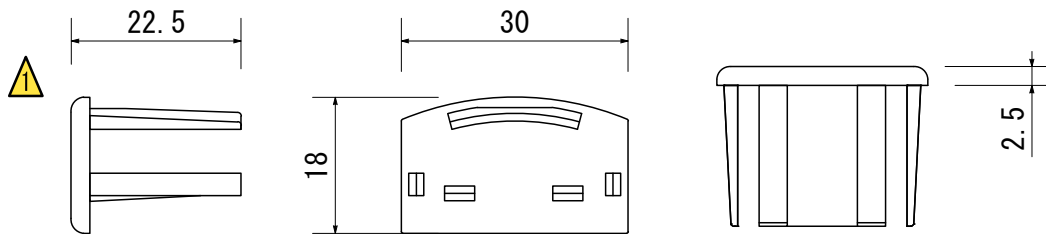



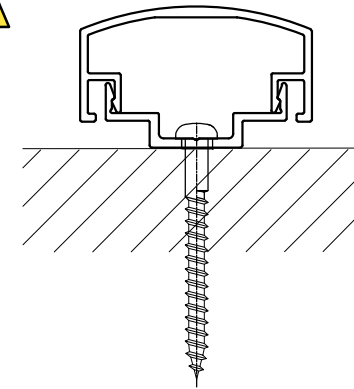

### Installation detail



			Product Name				Project Name	Creation Date	Page	Scale	Projection
	<b>Install</b>	Never strike extrusion directly with a hammer or rubber mallet. Use a pine plank between the tool and the extrusion to avoid surface damage or denting.	Ever Art Wood - Kabebari				Curve 30x18		36 of 37	1:1	
	<b>End caps</b>	Screw fix or apply exterior grade adhesive (Sikaflex) to secure cap to batten.	Approval	Chek	Drawing	Design	Customer	Distributor		Manufacturer	
No.	DATE							<b>covet</b>			

## Kabebari Batten Installation Guide

- Aluminium can be damaged if mishandled. Never strike directly with a hammer or rubber mallet. Use a pine plank between the striking rubber mallet and the extrusion to avoid surface damage or denting.
- Cut aluminium with a drop saw using an aluminium blade.
- Always cap ends of extrusions with supplied end caps or a flashing to avoid moisture ingress.
- Plastic end caps must be securely inserted with screws supplied or sikafelx applied to the inside of the extrusion before inserting. This will prevent slippage of the extrusion.
- Metal end caps (painted) must be screwed to the extrusion.
- All end caps can only be applied to straight 90 degree cuts. They cannot be applied to angle end cuts.
- Ensure appropriate screws are used to suit the substrate you are fastening to. It is important to use stainless steel or bi-metal screws for all metal surfaces impacted when fastening (i.e. furring channels, top hats, steel frames). This will prevent galvanic reaction between the screw/substrate and aluminium extrusion.
- Fasten at maximum 1 metre spans. Please contact Covet for further information.
- Always fasten the male (base) section first. The female (top section) clips over the top. They can also slide on if necessary.

			Product Name				Project Name	Creation Date	Page	Scale	Projection
	<b>Install</b>	Never strike extrusion directly with a hammer or rubber mallet. Use a pine plank between the tool and the extrusion to avoid surface damage or denting.	Ever Art Wood - Kabebari				Curve 30x18		37 of 37	1:1	
	<b>End caps</b>	Screw fix or apply exterior grade adhesive (Sikaflex) to secure cap to batten.	Approval	Chek	Drawing	Design	Customer	Distributor		Manufacturer	
No.	DATE							<b>covet</b>		